

EPSON® *Stylus*® COLOR 200

COLOR INK JET PRINTER

User's Guide

All rights reserved. No part of this publication may be reproduced, stored in a retrieval system, or transmitted in any form or by any means, electronic, mechanical, photocopying, recording, or otherwise, without the prior written permission of Seiko Epson Corporation. No patent liability is assumed with respect to the use of the information contained herein. Neither is any liability assumed for damages resulting from the use of the information contained herein.

Neither Seiko Epson Corporation nor its affiliates shall be liable to the purchaser of this product or third parties for damages, losses, costs, or expenses incurred by purchaser or third parties as a result of: accident, misuse, or abuse of this product or unauthorized modifications, repairs, or alterations to this product, or (excluding the U.S.) failure to strictly comply with Seiko Epson Corporation's operating and maintenance instructions.

Seiko Epson Corporation shall not be liable against any damages or problems arising from the use of any options or any consumable products other than those designated as Original EPSON Products or EPSON Approved Products by Seiko Epson Corporation.

EPSON, EPSON Stylus, and EPSON ESC/P are registered trademarks and EPSON ESC/P 2 is a trademark of Seiko Epson Corporation.

EPSON Connection is a service mark of Epson America, Inc.

Software 2000 is a trademark of Software 2000 Ltd.

Windows Printer driver copyright Software 2000 Ltd Oxford, England.

General Notice: Other product names used herein are for identification purposes only and may be trademarks of their respective owners. EPSON disclaims any and all rights in those marks.

The Energy Star emblem does not represent EPA endorsement of any product or service.

Copyright © 1996 by Epson America, Inc.

3/96



Printed on recycled paper with at least 10% post-consumer content

Printer Parts

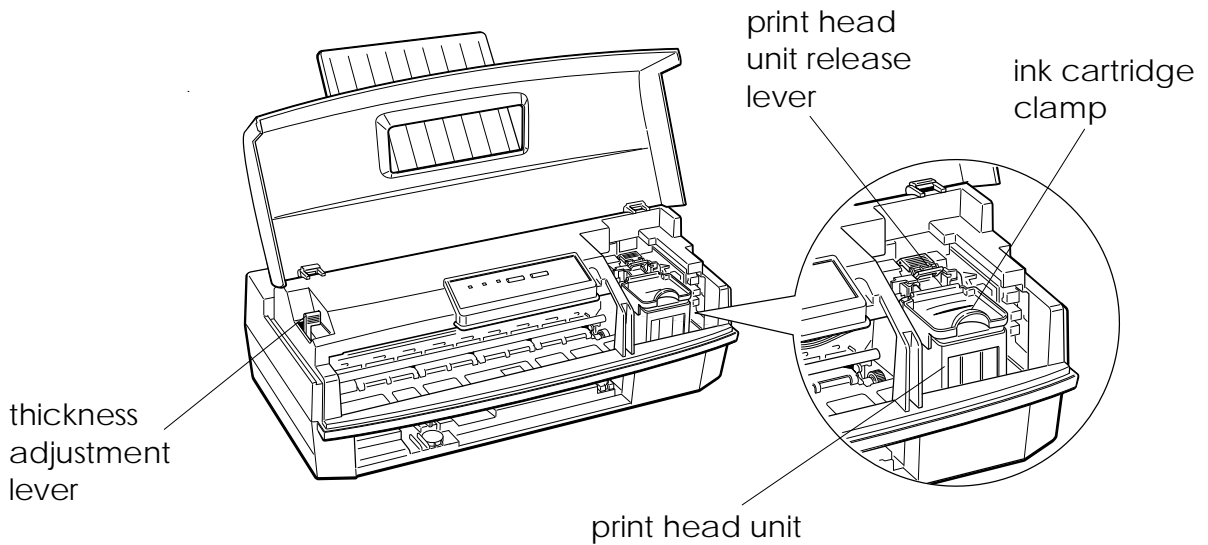
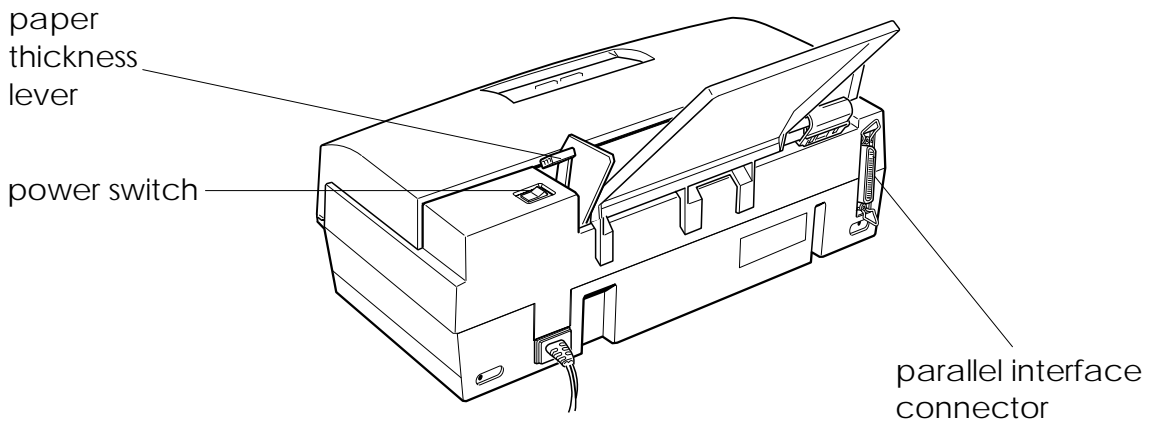
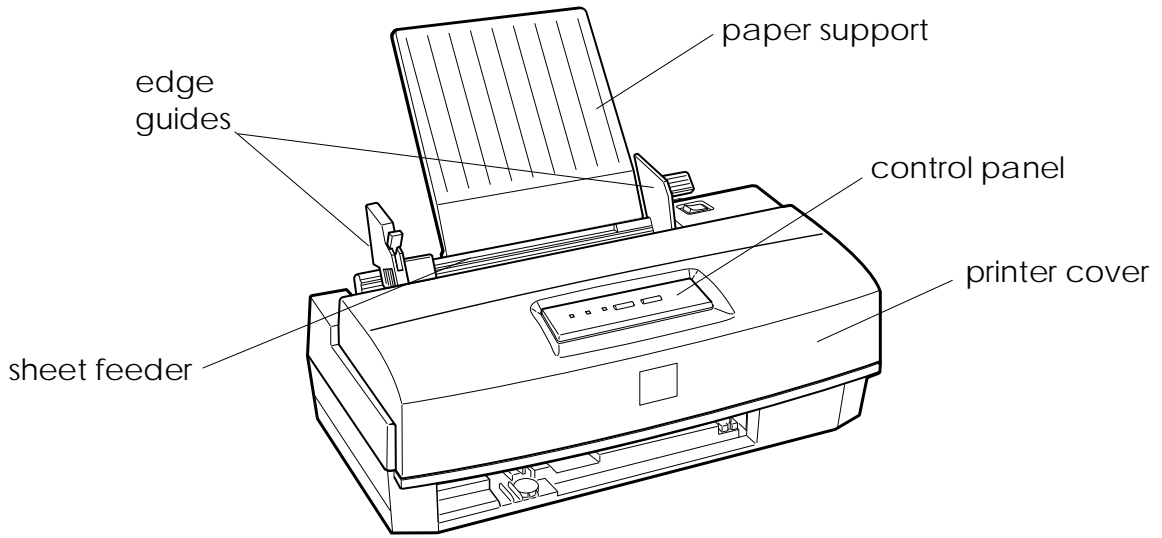

FCC Compliance Statement For United States Users

This equipment has been tested and found to comply with the limits for a Class B digital device, pursuant to Part 15 of the FCC Rules. These limits are designed to provide reasonable protection against harmful interference in a residential installation. This equipment generates, uses, and can radiate radio frequency energy and, if not installed and used in accordance with the instructions, may cause harmful interference to radio or television reception. However, there is no guarantee that interference will not occur in a particular installation. If this equipment does cause interference to radio and television reception, which can be determined by turning the equipment off and on, the user is encouraged to try to correct the interference by one or more of the following measures.

- Reorient or relocate the receiving antenna.
- Increase the separation between the equipment and receiver.
- Connect the equipment into an outlet on a circuit different from that to which the receiver is connected.
- Consult the dealer or an experienced radio/TV technician for help.

WARNING

The connection of a non-shielded equipment interface cable to this equipment will invalidate the FCC Certification of this device and may cause interference levels which exceed the limits established by the FCC for this equipment. It is the responsibility of the user to obtain and use a shielded equipment interface cable with this device. If this equipment has more than one interface connector, do not leave cables connected to unused interfaces. Changes or modifications not expressly approved by the manufacturer could void the user's authority to operate the equipment.

For Canadian Users

This digital apparatus does not exceed the Class B limits for radio noise emissions from digital apparatus as set out in the radio interference regulations of the Canadian Department of Communications.

Le présent appareil numérique n'émet pas de bruits radioélectriques dépassant les limites applicables aux appareils numériques de Classe B prescrites dans le règlement sur le brouillage radioélectrique édicté par le Ministère des Communications du Canada.

Contents

Introduction

Getting the Most Out of Your Printer	1
If You Are New to Color Printing	3
Energy Star Compliance	4
Energy-saving Tips	5
How to Use This Manual	5
Where to Get Help	6
Electronic Support Services	7
Important Safety Instructions	9

Chapter 1 Setting Up the Printer

System Requirements	1-2
Unpacking the Printer	1-3
Setting Up the Printer	1-4
Selecting a Location	1-4
Attaching the Paper Support	1-4
Plugging In and Turning On the Printer	1-5
Charging the Ink Delivery System	1-6
Checking the Paper Thickness Lever	1-14
Loading Paper	1-15
Testing the Printer	1-17
Connecting the Printer to Your Computer	1-18

Chapter 2 Installing and Using the Printer Software

Installing the Printer Software	2-2
Installing the Software for Windows 3.1	2-2
Installing the Software for Windows 95	2-5
Installing a Driver for DOS Programs	2-8
Accessing the Printer Driver	2-9
Accessing the Driver From Windows Applications	2-9
Accessing the Driver From Windows 3.1	2-10
Accessing the Driver From Windows 95	2-10

Using the Printer Driver	2-11
Changing Settings	2-14
Using Online Help	2-15
Accessing Online Help From Windows 3.1	2-15
Accessing Online Help From Windows 95	2-15

Chapter 3 Paper Handling

Choosing Paper and Other Media	3-2
Setting the Paper Thickness and Adjustment Levers	3-3
Paper Thickness Lever	3-3
Thickness Adjustment Lever	3-4
Loading Plain Paper	3-5
Loading Special Papers and Other Media	3-8
Loading Special Papers and Transparencies	3-8
Loading Envelopes	3-11

Chapter 4 Controlling the Printer

Managing Print Jobs	4-2
Using the Printer's Control Panel	4-5
Lights	4-5
Buttons	4-6
Using the Default Setting Mode	4-8

Chapter 5 Maintenance

Cleaning the Print Head	5-2
Changing the Print Head Unit	5-3
Replacing an Ink Cartridge	5-6
Selecting the Correct Ink Cartridges	5-7
Removing and Installing an Ink Cartridge	5-7
Cleaning the Printer	5-10
Transporting the Printer	5-11
Calibrating the Printer	5-12
Calibrating the Printer From Windows	5-13
Calibrating the Printer From DOS	5-14

Diagnosing Problems	6-2
Print Quality Problems	6-3
Problems With Printing	6-8
Paper Handling Problems	6-13
Paper Jam Problems	6-13
Paper Feeding Problems	6-14
Other Paper Handling Problems	6-14

Appendix A Technical Specifications

Printing	A-2
Paper	A-3
Ink Cartridges	A-6
Mechanical	A-7
Electrical	A-7
Environmental	A-8
Safety Approvals	A-8
Fonts	A-8
Parallel Interface Specifications	A-9
Pin Assignments	A-9
Reverse Channel	A-11
Timing Chart	A-14
Initialization	A-14
Default Settings	A-15

Appendix B Commands and Character Tables

Command List	B-2
Character Tables	B-3
International Character Sets	B-7
Characters Available With the ESC (^ Command	B-8

Glossary

Index

Introduction

The EPSON® Stylus® COLOR 200 is an affordable, high-quality ink jet printer that can print up to 16 million colors at high resolution to produce full-color, photo-quality images. It also produces realistic grayscale images, laser-quality text, and line art. The printer's ink jet technology allows it to operate quietly, keeping your workspace peaceful.

The Stylus COLOR 200 is easy to install and use. You simply set it up, connect it to your computer, and install the printer software, as described in this book. The printer has a built-in parallel interface so you can connect it to any IBM® PC compatible computer.

The printer software includes a “driver” that controls printing and lets you choose from a wide variety of printer settings. You can change settings to improve print quality, speed up printing, or achieve special printing effects. And to make your selections easy, the driver includes an option that analyzes each page and automatically adjusts the settings before printing it.

Getting the Most Out of Your Printer

To achieve the highest quality printout, you should know a few of the elements that contribute to outstanding color printing:

- ❑ **Resolution** is a measure of the amount of detail that can be represented on the page. The higher the resolution, the more detailed and realistic the image, and the longer it takes to print. For printed images, resolution is measured in dots per inch (dpi). Your printer has three resolutions: 720 dpi, 360 dpi, and Economy (180 dpi).

Use 720 dpi for the best possible images. For high-quality images in less time, use 360 dpi. When speed is important and draft quality is good enough, use Economy (180 dpi).

- ❑ **Paper type and quality** are very important. Although you get good results with plain bond paper, you will get better results by using coated or glossy papers because they do not absorb as much ink.

To ensure the best possible quality, EPSON offers special coated papers, glossy papers, and transparencies that are specially formulated for the inks used by the printer. You can order these products from EPSON Accessories at **(800) 873-7766** (U.S. sales only). In Canada, call **(800) BUY-EPSON** for sales locations. (For information about special papers and other media, see Chapter 3.)

- ❑ **EPSON ink cartridges** (black and color) are specially formulated to work with EPSON papers and your printer software to deliver the best looking images. Always use genuine EPSON ink cartridges and do not refill them. Other products may cause damage not covered by EPSON's warranty.
- ❑ **Printer driver settings** control every aspect of how your printer prints, so be sure to select the driver settings that are appropriate for your images each time you print.

The basic driver settings include document type, paper type and size, resolution, and print head unit. Optional settings that you may or may not need to check include halftoning, color adjustments, and the printing mode options described below.

- ❑ **Printing mode options** affect the speed and accuracy with which the print head sprays ink onto the paper. MicroWeave mode applies ink in an intricate pattern to eliminate the possibility of banding (light, horizontal lines) that can sometimes occur in normal mode. High Speed mode prints bidirectionally (one line from right to left and the next from left to right) to speed up printing. You should use MicroWeave mode when printing detailed graphic and photographic images. High Speed mode is good for all draft copies and for printing text; however, the vertical alignment in your images may not be as precise.

If You Are New to Color Printing

Color printing with the EPSON Stylus COLOR 200 produces amazing images, whether you print text, graphics, line drawings, photographs, or documents containing many different image types. However you use your color printer, keep the following in mind:

- ❑ Leave a large amount of hard disk space free to make room for your color images. A full-page color photographic image may require 40MB or more of disk space, depending on the resolution. To reduce file size, you can decrease the size and resolution of your images using your printer driver and application software.
- ❑ Color printing takes time because of the complex processing required to create a color image. How much time depends on the size and type of your image, the resolution you use, and the speed of your computer. However, the fantastic results make the time spent well worth it.

- ❑ Your screen colors will not exactly match the printed colors because your computer monitor and printer use different methods to produce the colors you see. If you scan images using a scanner, the image goes through another interpretive process that also affects the color.

Monitors and scanners produce colors by combining red, green, and blue—the RGB method. Monitor can produce up to 16 million colors by turning on and off the tiny red, green, and blue phosphors contained in each pixel on the screen. Colors produced this way differ from colors produced by your printer’s cyan, magenta, and yellow ink colors—the CMY method.

Your printer driver settings help you closely match colors for your image type, resolution, and paper or other media. If you need extreme precision in matching colors, you can use a color calibration system available with many software applications. If you use a scanner, make sure your scanning software is set to the correct setting for ink jet printers. Also, your application may include image editing capabilities that let you adjust the colors.



Energy Star Compliance

As an Energy Star Partner, EPSON has determined that this product meets the Energy Star guidelines for energy efficiency.

The EPA estimates that if all desktop computers, printers, and other peripheral devices met Energy Star standards, energy cost savings would exceed \$1 billion annually and carbon dioxide emissions would be reduced by 20 million tons.

All of EPSON’s ink jet printers conform to Energy Star standards.

Energy-saving Tips

Here are a few tips you can use to be even more energy-wise:

- ❑ If your monitor isn't Energy Star compliant, turn it off when you're not using it.
- ❑ Turn off your computer, printer, and monitor each day when you are done using them.
- ❑ Use the print preview option in your software so you can catch errors before you print something.
- ❑ If you have an electronic mail system available to you, send e-mail rather than memos. Not only is this faster, but you'll save paper and storage space too.

How to Use This Manual

This manual contains all the information you need to set up and use your printer.

Chapter 1, “Setting Up the Printer,” provides simple steps for setting up your printer, running its self test, and connecting it to your computer.

Chapter 2, “Installing and Using the Printer Software,” explains how to install and access the printer software and gives guidelines for selecting printer driver settings.

Chapter 3, “Paper Handling,” explains how to select the right paper or other media for your print job and load it in your printer.

Chapter 4, “Controlling the Printer,” provides instructions for managing the printer's operation using the Spool Manager, the printer's control panel, and Default setting mode.

Chapter 5, “Maintenance,” gives instructions for cleaning the print heads, changing the print head unit, replacing the ink cartridge, and cleaning, transporting, and calibrating the printer.

Chapter 6, “Troubleshooting,” contains guidelines for solving any print quality or printer operation problems you may have.

Appendix A, “Technical Specifications,” gives the specifications for the Stylus COLOR 200 printer.

Appendix B, “Commands and Character Tables,” lists the ESC/P 2™ emulation commands supported by the printer and shows the printer’s built-in character tables.

A **Glossary** and **Index** are included at the end of the book.

Where to Get Help

If you purchased your printer in the United States or Canada, EPSON provides customer support and service through a network of Authorized EPSON Customer Care Centers. EPSON also provides the following services when you dial **(800) 922-8911**:

- EPSON fax-on-demand technical information library
- Product literature on current and new products
- Assistance in locating your nearest Authorized EPSON Reseller or Customer Care Center
- Technical information on the installation, configuration, and operation of EPSON products
- Customer relations.

You can purchase ink cartridges, paper, parts, printed manuals, and accessories for EPSON products from EPSON Accessories at **(800) 873-7766** (U.S. sales only). In Canada, call **(800) BUY-EPSON** for sales locations.

If you purchased your printer outside the United States or Canada, contact your EPSON dealer or the marketing location nearest you for customer support and service.

If you need help with any software program you are using, see the documentation for that program for technical support information.

Electronic Support Services

If you have a modem, the fastest way to access helpful tips, specifications, drivers, application notes, and bulletins for EPSON products is through the online services below.

World Wide Web

If you are connected to the Internet and have a Web browser, you can access EPSON's World Wide Web site at **<http://www.epson.com>**. EPSON's home page links users to What's New, EPSON Products, EPSON Connection,SM Corporate Info, and EPSON Contacts. Link to the EPSON Connection for the latest drivers and FAQs (Frequently Asked Questions) and the EPSON Chat area. To get in touch with EPSON around the world, EPSON Contacts includes Contact Information for local EPSON subsidiaries.

EPSON FTP Site

If you have access to the Internet and an FTP client, you can download drivers, FAQs, and sample files from EPSON's FTP site. Use your FTP client or Web browser to log onto **<ftp.epson.com>** with the user name *anonymous* and your e-mail address as the password.

EPSON Fax-on-Demand service

You can access the EPSON fax-on-demand technical information library by calling **(800) 922-8911** or **(800) 442-2110**. To receive information, you must provide a fax number.

EPSON Download Service

You can call the EPSON Download Service at **(310) 782-4531**. Make sure your communications software is set to 8 data bits with 1 stop bit, no parity bit, and a modem speed up to 28.8 Kbps. See your communications software documentation for more information.

EPSON Forum on CompuServe

CompuServe® members can call the Epson America Forum on CompuServe. If you are already a member, simply type GO EPSON at the menu prompt to reach the Forum.

If you are not currently a member, you are eligible for a free introductory membership as an owner of an EPSON product. This membership entitles you to:

- An introductory credit on CompuServe
- Your own user ID and password
- A complimentary subscription to *CompuServe Magazine*, CompuServe's monthly publication.

To take advantage of this offer, call **(800) 848-8199** in the United States and Canada and ask for representative #529. In other countries, call the following U.S. telephone number: **(614) 529-1611**, or your local CompuServe access number.

Important Safety Instructions

Before using your printer, read the following safety instructions to make sure you use the printer safely and effectively.

- ❑ Turn off and unplug the printer before cleaning. Clean with a damp cloth only. Do not spill liquid on the printer.
- ❑ Do not place the printer on an unstable surface or near a radiator or heating vent.
- ❑ Do not block or cover the openings in the printer's cabinet or insert objects through the slots.
- ❑ Use only the type of power source indicated on the printer's label.
- ❑ Connect all equipment to properly grounded power outlets. Avoid using outlets on the same circuit as photocopiers or air control systems that regularly switch on and off.
- ❑ Do not let the power cord become damaged or frayed.
- ❑ If you use an extension cord with the printer, make sure the total ampere rating of the devices plugged into the extension cord does not exceed the cord's ampere rating. Also, make sure the total of all devices plugged into the wall outlet does not exceed 15 amperes.
- ❑ Except as specifically explained in this *User's Guide*, do not attempt to service the printer yourself.
- ❑ Unplug the printer and refer servicing to qualified service personnel under the following conditions:

If the power cord or plug is damaged; if liquid has entered the printer; if the printer has been dropped or the cabinet damaged; if the printer does not operate normally or exhibits a distinct change in performance. Adjust only those controls that are covered by the operating instructions.

Setting Up the Printer

System Requirements	1-2
Unpacking the Printer	1-3
Setting Up the Printer	1-4
Selecting a Location	1-4
Attaching the Paper Support	1-4
Plugging In and Turning On the Printer	1-5
Charging the Ink Delivery System	1-6
Checking the Paper Thickness Lever	1-14
Loading Paper	1-15
Testing the Printer	1-17
Connecting the Printer to Your Computer	1-18



Be sure to read all the sections in this chapter to ensure that you set up your printer properly.

System Requirements

To use your printer and its driver, we recommend that your system includes:

- ❑ An 80386/25 MHz or faster processor
- ❑ Microsoft® Windows® 3.1, Windows for Workgroups 3.1, or Windows 95
- ❑ At least 8MB of available RAM (more for Windows 95)
- ❑ A minimum of 10MB of hard disk space for storing images (40MB or more is recommended for color images)
- ❑ VGA or higher standard monitor
- ❑ A shielded, twisted-pair parallel cable (6 to 10 feet long) to connect your computer to the printer's parallel interface; the cable must have a D-SUB, 25-pin, male connector for your computer and a 36-pin, Centronics® compatible connector for the printer.

Unpacking the Printer

In addition to this *User's Guide*, your printer box should include a *Quick Setup* card, the printer software diskettes, a Notice Sheet, a registration card, and these items:

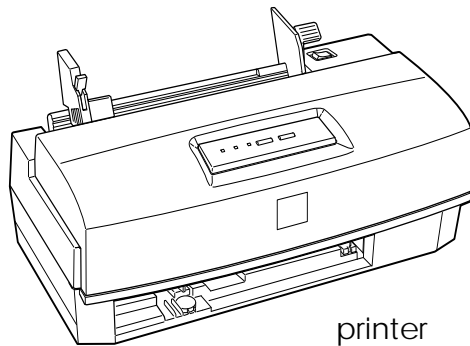

printer

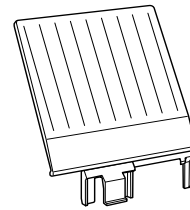

paper support

print head
storage box

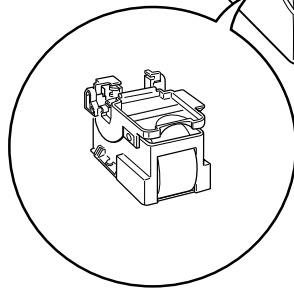
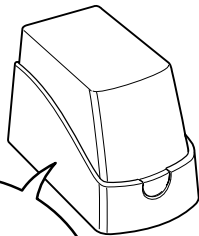

monochrome
print head

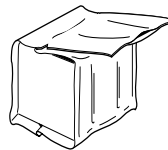

color ink cartridge

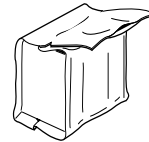

black ink cartridge

C **Caution:** *To avoid damaging the printer, you must remove all protective materials packed around and inside the printer before you set it up and turn on the power. Follow the directions on the Notice Sheet packed with the printer.*

Save all packaging and protective materials in case you need to transport the printer in the future. You should always transport it in its original packaging or equivalent materials.

Setting Up the Printer

The following procedures describe how to set up and test the printer before you connect it to your computer. Refer to the illustrations on the inside front cover of this manual to identify the main components while setting it up.

Selecting a Location

When choosing a location for the printer, select a surface that is flat, horizontal, and stable. Locate the printer away from the edge of your desk or table so that paper ejected from the front has room to land on a flat surface.

Avoid locations subject to rapid changes in temperature and humidity. Also keep the printer away from direct sunlight, heat sources, and sources of electromagnetic interference, such as the base unit of a cordless telephone.

Attaching the Paper Support

Insert the paper support into the slots at the back of the printer. Tilt the paper support slightly forward while inserting it.

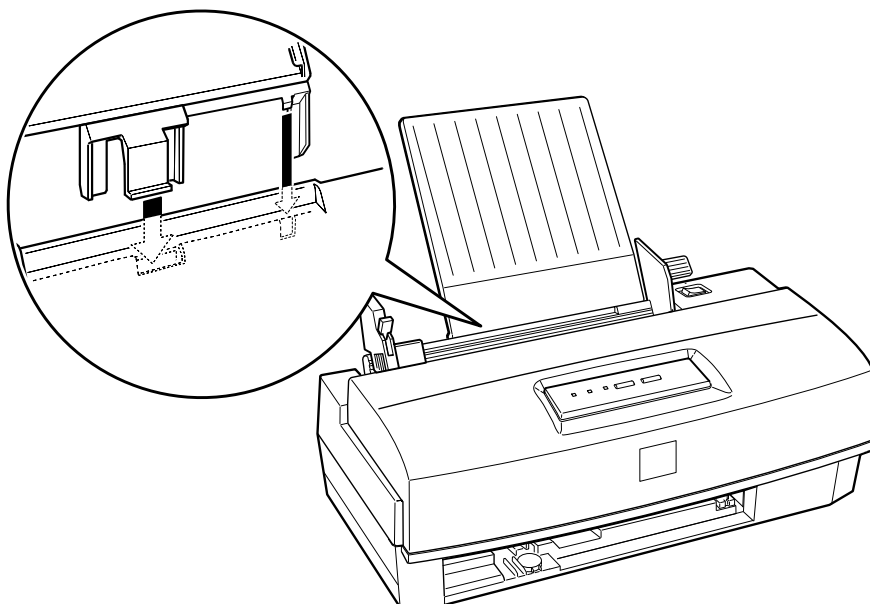

Plugging In and Turning On the Printer

Follow these steps to plug in and turn on your printer:

1. Make sure you have removed all protective packing materials from inside the printer. (See the Notice Sheet for more information.)
2. Make sure the printer is turned off by checking the position of the POWER switch, as shown below.

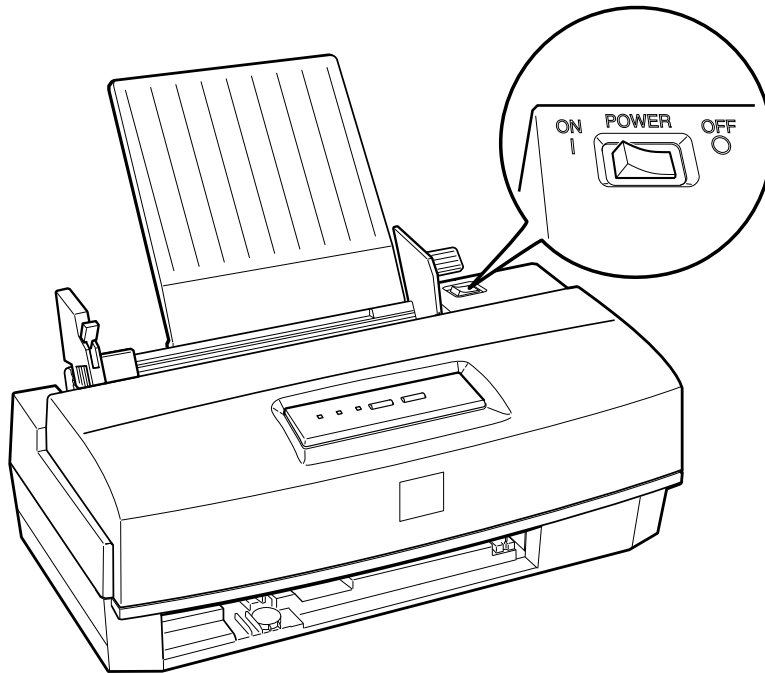

3. Plug the power cord into a properly grounded electrical outlet.
4. Turn on the printer by pressing the POWER switch.

Note:

The Power and Ink Out lights turn on to indicate that no ink cartridge is installed.

Charging the Ink Delivery System

Your printer comes with a color print head, installed in the printer, and a monochrome print head, packed in the plastic storage box. When you want to print in color, install the color print head unit with the color ink cartridge in the printer. When you want to print in black, install the monochrome print head unit and black ink cartridge in the printer.

Note:

When printing a page that does not include color, using the black ink cartridge is much faster and more economical. However, the color ink cartridge can print composite black. Composite black is a mixture of the inks in the color ink cartridge that closely resembles black ink.

When you first set up the printer, you need to completely charge its ink delivery system by first installing the color ink cartridge and then replacing it with the black print head unit and cartridge. Follow all the steps in this section.

Note:

Even if you don't plan to use the black ink cartridge immediately, you still need to install it to charge the ink delivery system.

Once both ink delivery systems are charged, you can easily switch between color and monochrome printing as needed. Follow the instructions in Chapter 3.

Warning:

W *The ink cartridges are self-contained units. Under ordinary use, ink will not leak from a cartridge. If ink gets on your hands, wash them thoroughly with soap and water. If ink gets into your eyes, flush them immediately with water.*

Caution:

C *Do not open the ink cartridge packages until just before you install them or they may become dry.*

Installing the color ink cartridge

Follow these steps to install the color ink cartridge:

1. Make sure the printer is turned on.

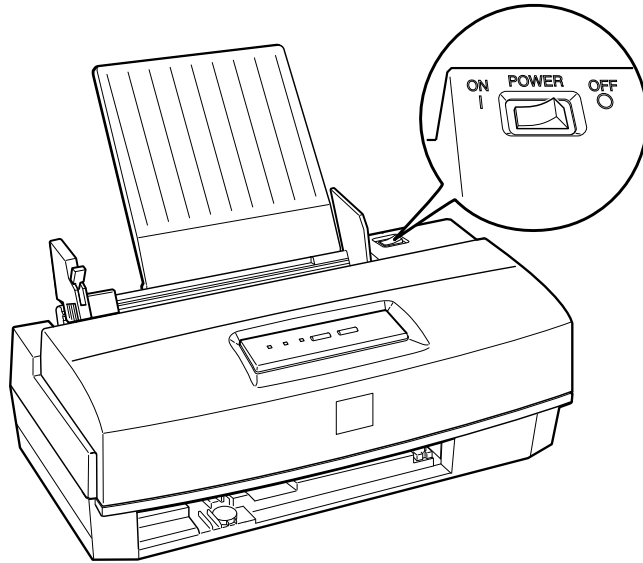

2. Raise the printer cover by lifting the edges, as shown below.

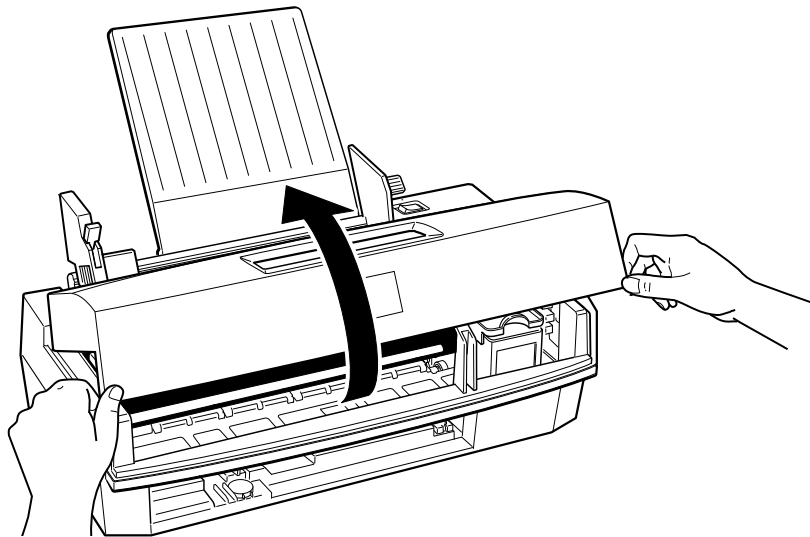

3. Hold down the Load/Eject button for about five seconds until the print head moves slightly left, to the ink cartridge install position. The Power light begins flashing.

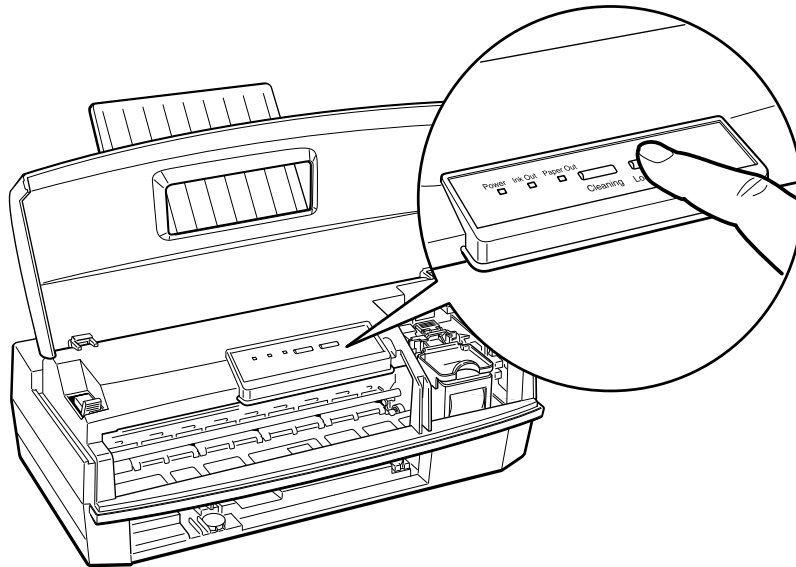

C **Caution:**
Never move the print head by hand; always use the Load/Eject button to move it.

4. Raise the ink cartridge clamp to open the print head unit.

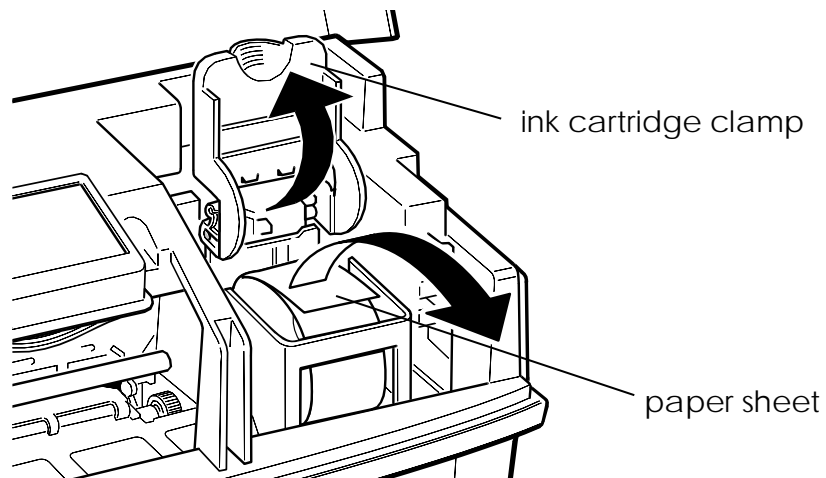

5. Remove the protective paper sheet.

- Open the foil ink cartridge packages and take out the cartridges. Remove the tape seal from the top of each one. Set the black cartridge aside for now.

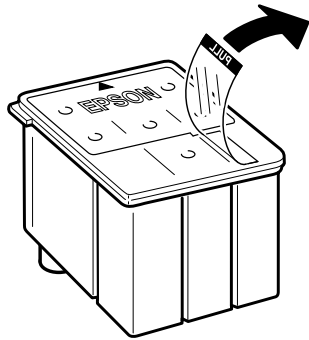

color cartridge

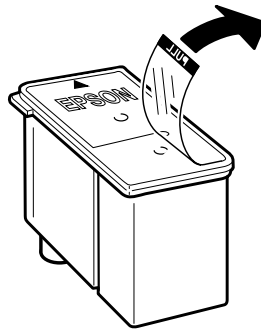

black cartridge

C **Caution:** *You must remove the tape seal from the top of each cartridge; leaving the tape on will permanently damage a cartridge. Do not remove the clear seal from the bottom of the cartridge; ink will leak out.*

- Lower the color ink cartridge into the print head unit with the label facing up and the arrow on the top of the cartridge pointing toward the back of the printer.

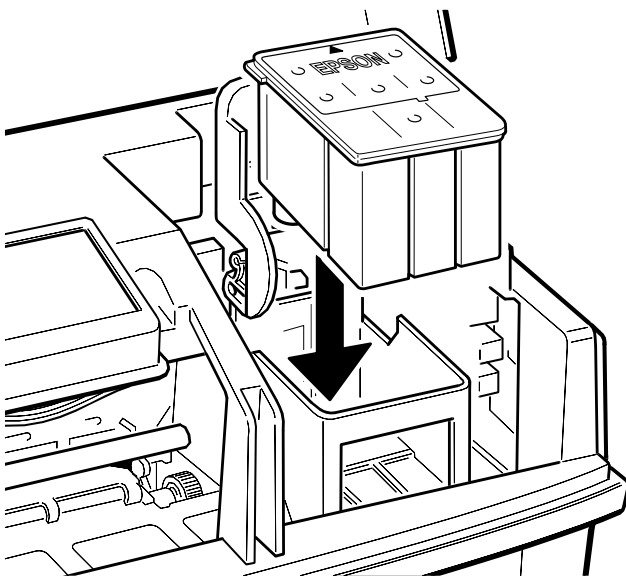

8. Press down the ink cartridge clamp until it locks in place. You will feel some resistance.

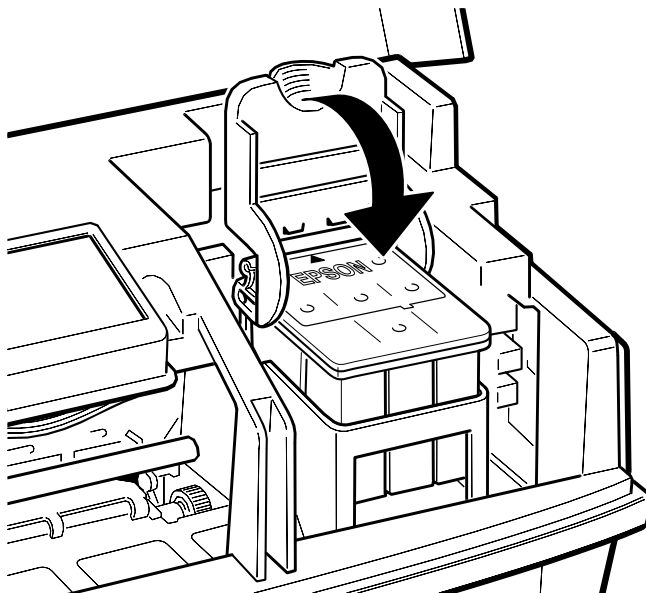

C **Caution:** Once you install an ink cartridge, do not open the ink cartridge clamp again or remove the cartridge except to replace it with a new one. Once you remove a cartridge, do not reuse it; you may damage the print head.

9. Press the Load/Eject button again to return the print head to its home position. (Even if you do not press Load/Eject, the print head moves back to its home position about 60 seconds after you close the clamp.)

The printer charges the ink delivery system for about two minutes. During this time, the Power light flashes. When the printer is finished charging, the Power light stays on.

C **Caution:** Never turn off the printer while the Power light is flashing.

Installing the black ink cartridge

Follow these steps to remove the color print head unit and install the monochrome print head unit and black ink cartridge:

1. Make sure the printer is on and the printer cover is open.
2. Hold down the Load/Eject button for about five seconds until the print head unit moves slightly left to the ink cartridge install position. The Power light flashes.
3. Raise the blue print head unit release lever as far as it will go.

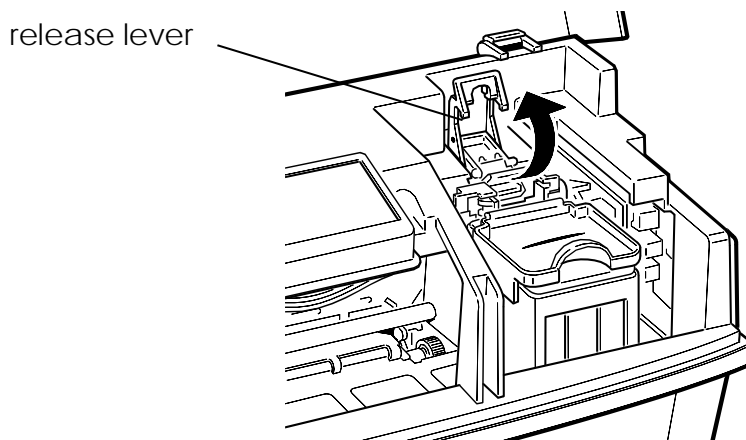

C **Caution:**
Do not lift up the ink cartridge clamp; the ink cartridge and print head may become unusable.

4. Grasp both sides of the print head unit and carefully lift it out of the printer. Place the print head unit on a flat, clean surface.

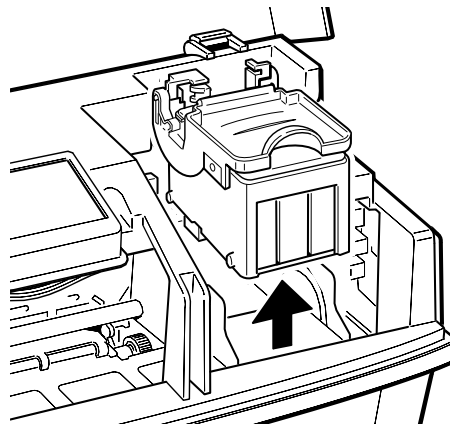

C **Caution:**
Do not touch the electrical contacts on the back and bottom of the print head unit or inside the printer; you may damage them.

5. Remove the monochrome print head unit from its storage box by pressing on the notch as shown. Place the color print head unit in the box. Always store the unused print head unit in this box to protect its delicate components.

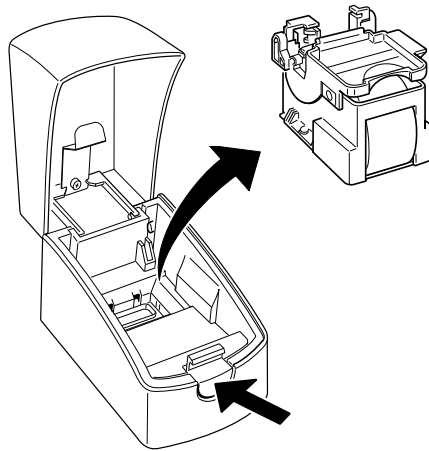

6. Carefully insert the monochrome print head unit into the printer with the electrical contacts and print head facing the back of the printer.

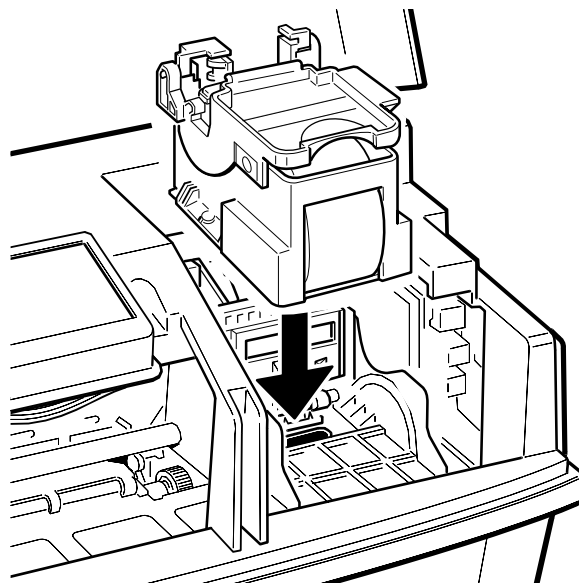

7. Press down the print head unit release lever until it clicks into place.

C **Caution:**
If the Power and Ink Out lights are flashing, remove the print head unit (beginning at step 3) and reinsert it.

8. Open the ink cartridge clamp and remove the protective paper sheet.
9. Lower the black ink cartridge into the print head unit with the label facing up and the arrow on the top of the cartridge pointing toward the back of the printer.
10. Press down the ink cartridge clamp until it locks in place. You will feel some resistance.

C **Caution:**
Once you install an ink cartridge, do not open the ink cartridge clamp or remove the cartridge except to replace it with a new one. Once you remove a cartridge, do not reuse it; you may damage the print head.

11. Press the Load/Eject button again to return the print head to its home position. (Even if you do not press Load/Eject, the printer moves the print head back to its home position about 60 seconds after you close the clamp.)

After you install the black ink cartridge, the printer charges the ink delivery system for about one minute. During this time, the Power light flashes. When the printer finishes charging, the Power light stays on.

C **Caution:**
Make sure the printer completes the ink charging process even if you plan to reinstall the color print head unit. If charging is not completed, the printer may be damaged.

12. Close the printer cover.

C **Caution:**
Never turn off the printer while the Power light is flashing.

When you switch between print head units, always leave the ink cartridge installed. Once you remove a cartridge, do not reuse it. Reusing a cartridge that has been removed may damage the print head.

Use only genuine EPSON ink cartridges and do not refill them. Other products may cause damage not covered by EPSON's warranty.

When you want to print in color again, replace the monochrome print head unit with the color print head unit as described in Chapter 5.

Checking the Paper Thickness Lever

Before you load paper, make sure that the paper thickness lever, which controls the distance between the paper and the printer carriage, is set correctly. The paper thickness lever is on the top right side of the printer, next to the paper support. For now, it should be set to the plain paper setting (forward).

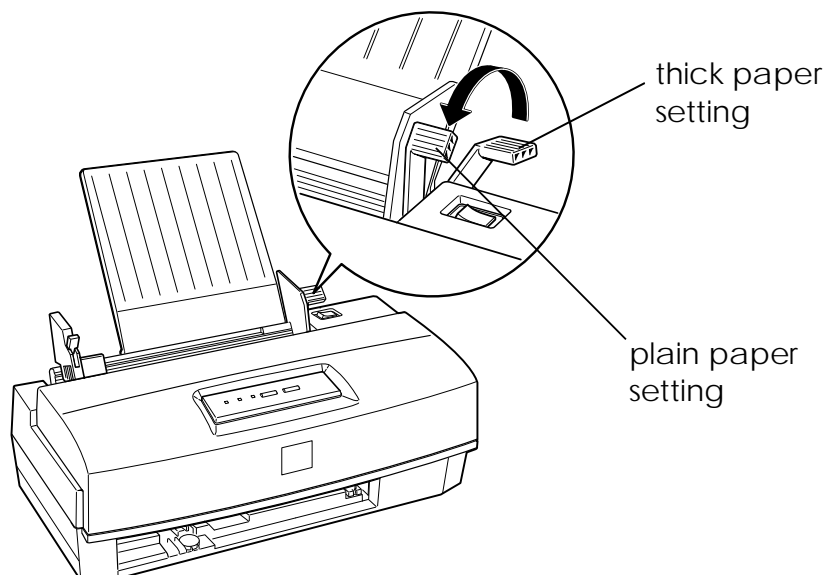

For instructions on setting the lever for thick paper (or other special media), see Chapter 3.

Loading Paper

This section explains how to load up to 100 sheets of plain bond paper in the sheet feeder. (For instructions on loading coated or glossy paper, envelopes, or transparencies, see Chapter 3. For paper specifications, see Appendix A.)

Always load plain paper with the printable surface facing up. The printable surface is marked with an arrow on most paper packaging.

1. Push down the left edge guide lock lever; then slide the left edge guide to the left as far as it will go.

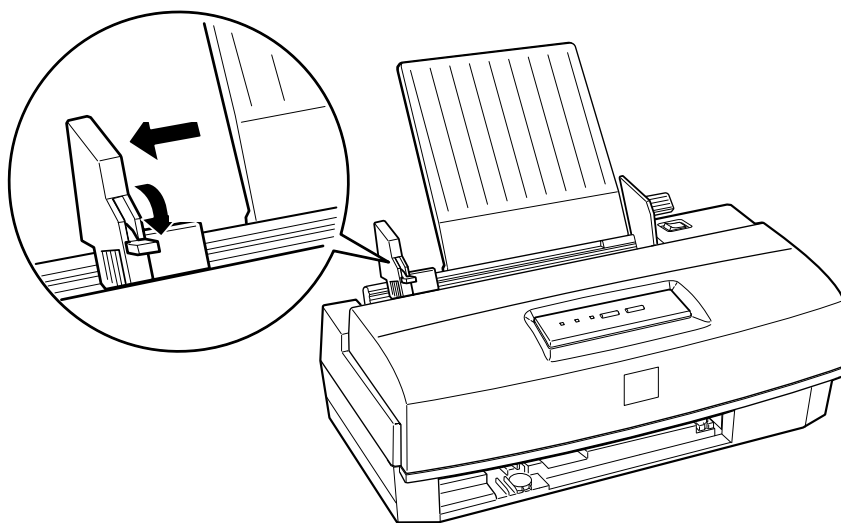

2. Load a stack of paper, printable side up, so that its right edge rests against the right side of the sheet feeder. Do not load paper above the arrow mark inside the left edge guide of the sheet feeder.

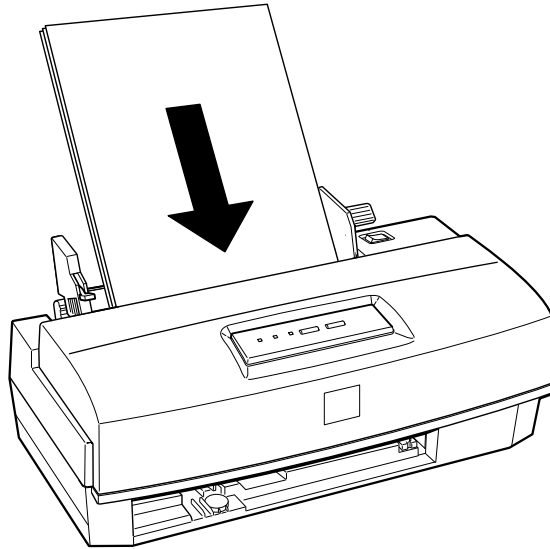

3. Slide the left edge guide against the left edge of the paper; then push up the lock lever to secure its position.

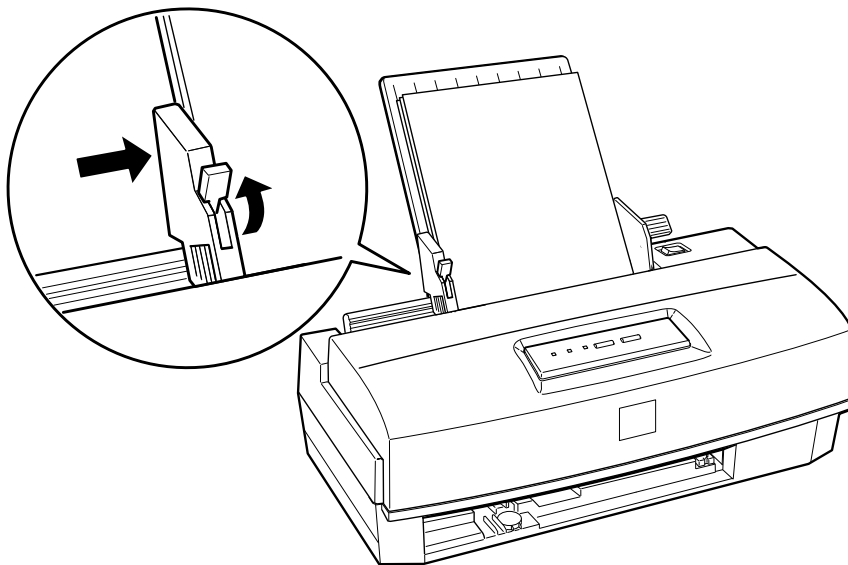

4. Remove the paper, fan the stack, and tap the edges against a flat surface to even them up.

5. Reload the paper straight down into the printer as shown. Then rest it against the paper support.

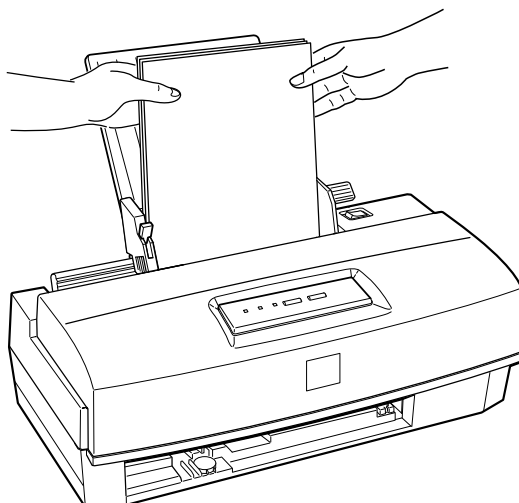

Testing the Printer

Before continuing, test the printer to make sure it is functioning properly. Make sure you loaded paper that is at least 8.25 inches (210 mm) wide.

1. Press the POWER switch to turn off the printer.

C **Caution:** *Never turn off the printer by unplugging it or turning off a power strip. Always turn it off with the POWER switch.*

2. Hold down the Cleaning button while pressing the POWER switch to turn on the printer. Keep holding down Cleaning until the printer begins feeding a page. The test prints in black on the first and last lines of the first sheet to measure the page length.
3. After the first page prints, press Load/Eject to print the next page containing character samples of the internal fonts and, when the color print head is installed, available colors.
4. To end the self test, wait until the printer ejects the paper and then turn off the printer.

If the quality of the test output is not suitable, you may need to clean the print head; see Chapter 5 for instructions.

Connecting the Printer to Your Computer

You need a shielded, twisted-pair parallel cable (6 to 10 feet long) to connect your computer to the printer's built-in parallel interface. The cable must have a D-SUB, 25-pin, male connector for your computer and a 36-pin, Centronics compatible connector for the printer.

Follow these steps to connect the cable:

1. Make sure both the printer and computer are turned off.
2. Plug the 36-pin end of the cable securely into the printer's interface connector. Then squeeze the wire clips together until they lock in place on both sides. (If your cable has a ground wire, attach it to the ground connector below the interface connector.)

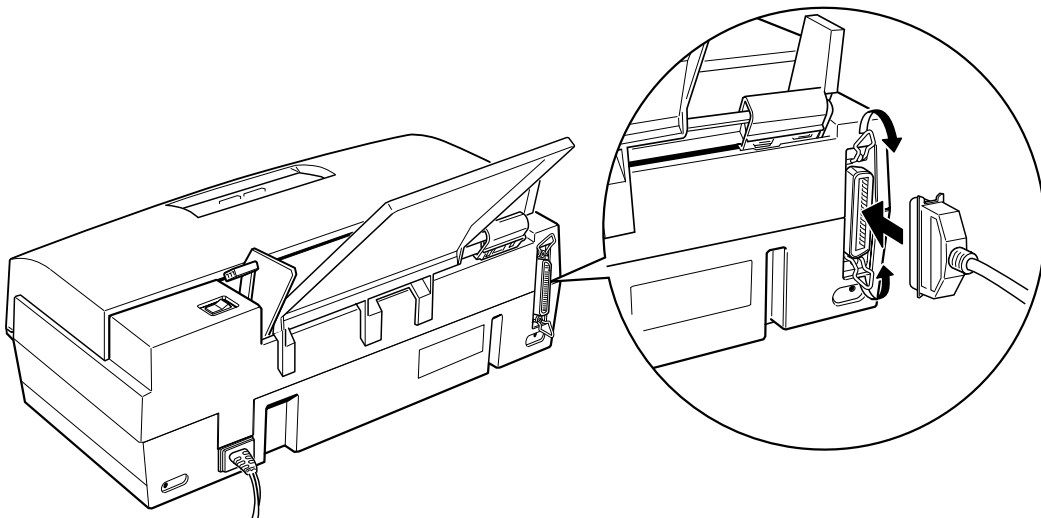

3. Plug the 25-pin end of the cable into the computer's parallel interface. (See your computer manual, if necessary.)
4. Turn on the printer by pressing the POWER switch and then turn on your computer.

Installing and Using the Printer Software

Installing the Printer Software	2-2
Installing the Software for Windows 3.1	2-2
Installing the Software for Windows 95	2-5
Installing a Driver for DOS Programs	2-8
Accessing the Printer Driver	2-9
Accessing the Driver From Windows Applications	2-9
Accessing the Driver From Windows 3.1	2-10
Accessing the Driver From Windows 95	2-10
Using the Printer Driver	2-11
Changing Settings	2-14
Using Online Help	2-15
Accessing Online Help From Windows 3.1	2-15
Accessing Online Help From Windows 95	2-15

This chapter describes how to install and use the EPSON Stylus COLOR 200 printer software on your computer.

The printer software includes a printer driver, which allows your computer to control the printer; you must install it to use the printer. The printer driver lets you choose from a wide variety of settings to customize the appearance of your printed documents.

The printer software also includes the Spool Manager, which manages your printing, and the Calibration Utility, which you can use to adjust the vertical alignment of your printouts. See Chapter 4 for information on the Spool Manager and Chapter 5 for instructions on using the Calibration Utility.

Note:

Be sure to make backup copies of your software diskettes.

Installing the Printer Software

If you are using Windows 3.1, follow the steps in the next section to install the printer software. If you are running Windows 95, see page 2-5 for instructions.

Installing the Software for Windows 3.1

1. Make sure your printer and computer are turned on and Windows Program Manager is running.
2. Insert the Windows Setup disk 1 in a diskette drive.
3. In the File menu, select Run. You see the Run dialog box.
4. In the Command Line box, type A:SETUP (or B:SETUP if you inserted the diskette in drive B). Press Enter or click OK.

5. When you see the EPSON Printer Utility Setup dialog box, highlight Epson Stylus COLOR 200 and click OK. The installation program begins copying the files. You see a screen showing the progress of the installation as it proceeds.
6. Follow the prompts on the screen to install the software.

After a few moments, the installation program creates the EPSON program group in Windows containing these icons:

Spool Manager
EPSON Printer Calibration
EPSON Stylus COLOR 200 Help
EPSON Stylus ReadMe

7. When you see the message that the installation is complete, click OK to exit Setup.

The installation program automatically selects the EPSON Stylus COLOR 200 printer as your default printer for Windows applications. It also assigns the printer driver to port LPT1. If you are happy with this configuration, go to page 2-9 for information on accessing the driver. If you need to change the default printer driver or the port assignment, see the next section.

Note:

If you installed the printer software using Windows 3.1 and will upgrade to Windows 95 later, you will need to reinstall your software using the steps beginning on page 2-5 after you install Windows 95. This procedure sets up the driver correctly for Windows 95.

Changing the default printer or printer port

If you do not want to use the EPSON Stylus COLOR 200 printer driver as your default printer in Windows or if you want to use it on a different printer port, follow these steps:

1. In the Main window, double-click the Control Panel icon.
2. Double-click the Printers icon. The Printers dialog box appears.
3. To change the default printer, in the Installed Printers drop-down list, select the printer you want to use as your default printer. Then click the Set As Default Printer button.

If you do not need to change the printer port assignment for the EPSON Stylus COLOR 200 printer, go to step 8.

4. To change the port assignment, select EPSON Stylus COLOR 200 in the Installed Printer drop-down list.
5. Click the Connect button. You see the Connect dialog box.
6. In the Ports drop-down list, select the port to which you want to assign the EPSON Stylus COLOR 200 printer. (Click Help for instructions on selecting other options in the Connect dialog box.)
7. Click OK to close the Connect dialog box.
8. Click Close to exit the Printers dialog box.
9. Close the Control Panel window.

See page 2-11 for instructions on using the printer driver.

Installing the Software for Windows 95

Follow these steps to install the printer driver using the Windows 95 plug-and-play capabilities:

1. Make sure the printer is connected to the computer's parallel port.
2. Turn off the printer and your computer, if they are on.
3. Turn on the printer first; then turn on the computer. Your computer begins loading Windows 95.
4. If you defined a password, enter it at the prompt. You see the New Hardware Found screen.

Note:

If you do not see the New Hardware found screen, follow the procedure under "Installing the driver while running Windows 95" on page 2-7 instead.

5. Your printer model name is displayed on the screen. Click the Driver from disk provided by hardware manufacturer button. Do not select any of the other buttons.

Note:

The next time you turn on or restart your computer after installing the driver, Windows 95 may display the New Hardware Found screen again. In this case, select the Do not install a driver radio button; then click OK. This screen will not appear again.

6. Click OK. You see the Install From Disk screen.
7. Insert the Windows Setup disk 1 in a diskette drive.

8. If you inserted the diskette in drive A, click OK. Otherwise, change the drive letter in the Copy manufacturer's files from box and click OK.
9. Make sure your printer model name appears in the next screen and click OK.
10. At the next screen you can give the printer a unique name. We recommend that you keep the model name, but you can type a new one in the Printer name box, if desired.

To use the printer as the default printer for all Windows 95 applications, select Yes (No is the default).

11. Click the Finish button.
12. Follow the prompts on the screen to install your software.

After the program has installed all the files, it creates an Epson folder containing the following icons:

- Spool Manager
- EPSON Printer Calibration
- EPSON Stylus COLOR 200 Help
- EPSON Stylus ReadMe

13. When the installation is complete, click OK.

The Setup program adds an icon to the Windows 95 Printers group using the printer name you selected.

Your printer driver is now installed. Go to page 2-9 for information on accessing and using the driver.

Installing the driver while running Windows 95

If you had trouble installing the printer driver using the plug-and-play feature, follow these steps to install the printer driver:

1. Make sure Windows 95 is running.
2. Insert the Windows Setup disk 1 disk in a diskette drive.
3. Double-click the My Computer icon.
4. Double-click the appropriate drive icon: 3½ Floppy [A:] or 3½ Floppy [B:].
5. Double-click the Setup icon. The EPSON Printer Utility Setup dialog box appears.
6. Select Stylus COLOR 200 in the Printer Model tab; then click OK to start the printer driver installation.
7. Follow the prompts on the screen to install the software.

After the program has installed all the files, it creates an Epson folder containing the following icons:

- Spool Manager
- EPSON Printer Calibration
- EPSON Stylus COLOR 200 Help
- EPSON Stylus ReadMe

8. When the installation is complete, click OK.

For information on accessing the driver, see “Accessing the Driver From Windows 95,” on page 2-10.

Installing a Driver for DOS Programs

Most DOS software programs include drivers for EPSON ESC/P 2™ printers. If the Stylus COLOR 200 driver is not listed in your software, choose the first printer available in the lists below. Also check with your software manufacturer to see if a Stylus COLOR 200 driver is available or is included with a new version of your software.

When printing in color as well as black and white, select:

LQ-860
LQ-2550

When printing black and white only, select:

LQ-870/1170
LQ-570(+)/1070(+)
SQ-870/1070
LQ-850
LQ-500

Note:

These drivers let you use your printer but do not support some features, such as 720 dpi and MicroWeave.

Accessing the Printer Driver

You can access the driver in different ways, depending on how you want to use the settings you select:

- ❑ If you want the changes to apply only to the document(s) you will print in a particular Windows application, see the following section.
- ❑ If you want the settings to apply to all Windows applications, access the driver as described on page 2-10 for either Windows 3.1 or Windows 95.

Accessing the Driver From Windows Applications

If you want to change the driver settings only for the application you are currently using, you can access the driver by choosing Print or Print Setup from the File menu of your software program. If you choose Print Setup, you access the printer driver directly and see the Main menu tab shown on page 2-11.

If you choose Print, you first see a Print dialog box. The Print dialog box contains the settings you change most often, including the number of copies and the print range. To access the printer driver settings, choose the Printer, Setup, Properties, or Options button. (You may need to select another option, depending on your software program.)

Note:

The printer driver settings you select through your Windows application apply only for the duration of your session with that application. Once you exit the application, the driver settings return to the default values selected through the Windows 3.1 Control Panel or Windows 95 (or the driver's defaults).

Accessing the Driver From Windows 3.1

Follow these steps to access the driver from the Windows Control Panel:

1. Double-click the Control Panel icon in the Main program group.
2. Double-click the Printers icon.
3. Choose EPSON Stylus Color 200 from the list of Installed Printers.
4. Choose Setup. You see the Main menu tab, shown on page 2-11.

Accessing the Driver From Windows 95

Follow these steps to access the driver from the Windows 95 My Computer group:

1. Double-click the My Computer icon.
2. Double-click the Printers icon.
3. Right-click the EPSON Stylus COLOR 200 icon (or double-click the icon and then pull down the Printer menu).
4. Select Properties.
5. Click the Main tab. You see the Main menu tab, shown on page 2-11.

Using the Printer Driver

However you accessed the printer driver, you see the Main menu tab:

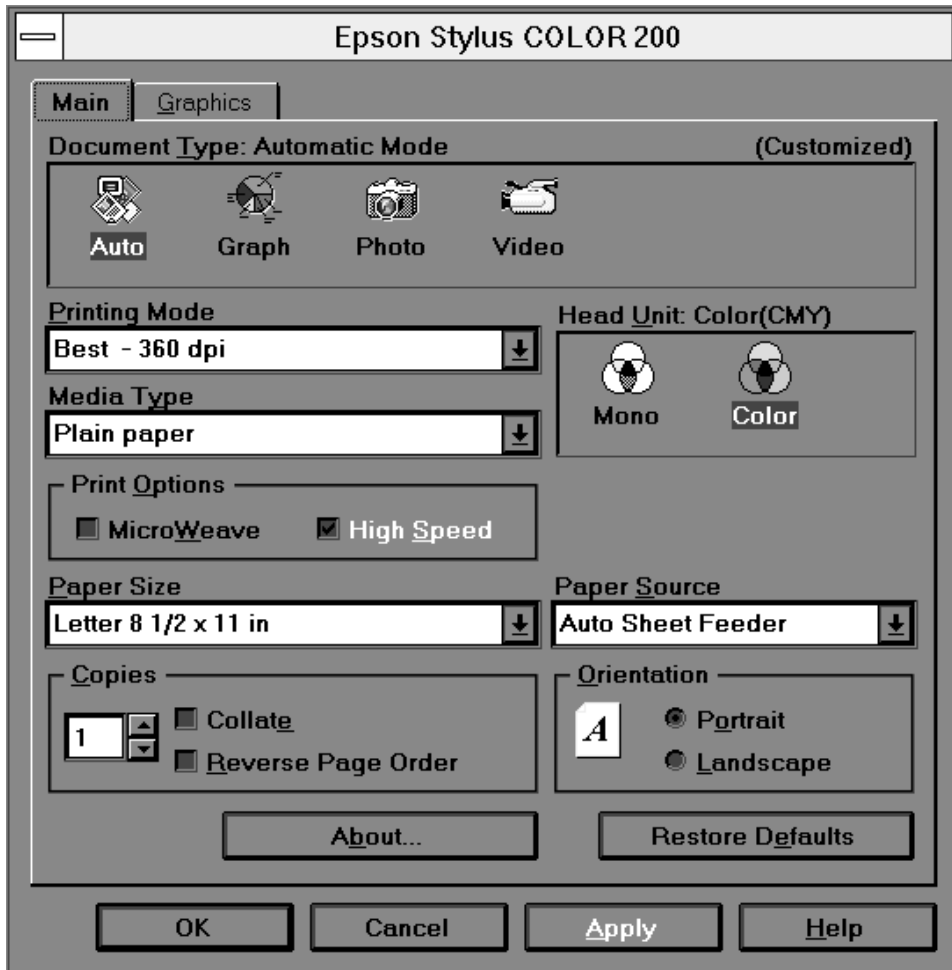

There are two menu tabs of printer driver settings: Main (shown above) and Graphics. These settings, which are listed in the tables on pages 2-13 and 2-14, let you control the appearance of your printed documents. All the driver settings are preset to default values which produce good quality output for the most common types of documents.

The printer driver also includes an Auto (Automatic) setting for Document Type. When Auto is selected for Document Type, the driver automatically chooses the best print settings for your document by analyzing the different types of data to be printed. It adjusts the Color Matching, Color Balance, and Halftoning settings for each object on the page to produce the best printed results. It is a good idea to try printing your document with Auto Document Type selected before changing any other settings in the driver.

Before printing, you should always check the following settings on the Main menu tab to make sure the driver selections are appropriate for the media you are using:

- Document Type—the type of image to be printed: business graphics, photographs, text, etc.
- Printing Mode—resolution: 720 dpi, 360 dpi, or Economy (180 dpi)
- Head Unit—the color or monochrome print head currently installed
- Media Type—the type of paper or other media you are using
- Paper Size—the size of paper you have loaded.

The best way to learn about your printer driver is to use the driver's extensive online help. It explains all the options available for each setting and also describes how to use the printer driver. See "Using Online Help" on page 2-15. For general information on changing settings, see page 2-14.

The following tables summarize the settings available in each menu tab (with default values in bold type). Because the driver software is updated periodically, some of your options may be slightly different than the ones shown here; see your printer driver's online help for more information.

Main menu settings

Setting	Options
Document Type	Auto (Automatic mode) Graph (Business Graphics) Photo (Photographic Images) Video (Video/Digital Camera) Economy (Monochrome) *
Head Unit	Mono (Monochrome Printing) Color (Full Color Printing)
Printing Mode	Super - 720 dpi Best - 360 dpi Economy (180 dpi)
Media Type	Plain paper Special coated paper - 360 dpi Special coated paper - 720 dpi High-quality glossy paper Transparency
Print Options	MicroWeave (On, Off) High Speed (On , Off)
Paper Size	A4 210 x 297 mm A4 (Centered) 210 x 297 mm B5 182 x 157 mm Letter 8 1/2 x 11 in Letter (Centered) 8 1/2 x 11 in Legal 8 1/2 x 14 in Legal (Centered) 8 1/2 x 14 in Envelope #10 4 1/8 x 9 1/2 in Envelope DL 110 x 220 mm Statement 5 1/2 x 8 1/2 in Executive 7 1/2 x 10 in A6 Index card (not used) User Defined
Copies	Number (1-99) Collate (On, Off) Reverse Page Order (On, Off)
Orientation	Portrait or Landscape
Paper Source	Auto Sheet Feeder

* The Economy Document Type option appears only when you select Mono for the Head Unit setting.

Graphics menu settings

Setting	Options
Color Matching *	Disabled Use Windows' matching Use Driver's matching Match for business graphics Match for photo images Match for logo
Color Balance *	Saturation -50% - 0% - +50% Red Strength -50% - 0% - +50% Green Strength -50% - 0% - +50% Blue Strength -50% - 0% - +50%
Halftoning **	No halftoning Error diffusion Dithering A Dithering B

* These options work as toggles, so only one appears in the menu at a time.

** There is no default setting for Halftoning; the setting is determined automatically depending on the Document Type setting.

Changing Settings

To change a setting in the printer driver, click the menu tab you want to see and click the setting you want to change. Use the scroll arrows or click the appropriate radio button to choose the desired option. Do this for each setting you want to change and then click the Apply button at the bottom of the screen to save your settings. Go to the other tab (if necessary) and do the same.

If you make one or more changes but then decide you want to go back to the default settings, select Restore Defaults. You can do this before or after applying your changes.

When you finish making changes, click OK to save the settings and close the driver.

If you make changes before selecting Apply, and you want to cancel them, click the Cancel button. This closes the printer driver.

Using Online Help

For complete information about using the printer driver, you can easily access online help any time. It provides detailed descriptions of the different settings and options.

Note:

Online help is not available for DOS applications.

Accessing Online Help From Windows 3.1

To access online help from the printer driver menus while you are in a Windows application, click the Help button at the bottom of the menu tab. Then select a help topic.

To access online help from Program Manager, open the EPSON program group and click the EPSON Stylus COLOR 200 Help icon. You see the help contents window.

If you need instructions for how to use help, click the Help button in the help screens.

Accessing Online Help From Windows 95

To access online help from the printer driver while you are in a Windows application, click the Help button at the bottom of the menu tab. Then select the topic you need help with.

For specific help related to any item in the menus, right-click the item, then click the What's This? prompt.

To access online help from Start, click the Start button, point to Programs, and Epson, and then click EPSON Stylus COLOR 200 Help. You see the help contents window. If you need instructions for how to use help, click the Help button in the help screens.

Paper Handling

Choosing Paper and Other Media	3-2
Setting the Paper Thickness and Adjustment Levers	3-3
Paper Thickness Lever	3-3
Thickness Adjustment Lever	3-4
Loading Plain Paper	3-5
Loading Special Papers and Other Media	3-8
Loading Special Papers and Transparencies	3-8
Loading Envelopes	3-11

Read this chapter for information about choosing and loading the best paper and other media for your printing needs.

Choosing Paper and Other Media

You can use most plain paper with your printer and achieve good results. Coated and glossy papers give you better results because they reduce the amount of ink that is absorbed.

However, if the coated or glossy paper does not absorb enough ink, the ink can smear.

To ensure the best results, EPSON provides special papers and transparencies that are formulated for the inks used in EPSON ink jet printers. These papers include the following:

- ❑ **EPSON special coated paper for 360 dpi.** Use this paper for best results when printing at 360 dpi.
- ❑ **EPSON special coated paper for 720 dpi.** Use this paper for best results when printing at 720 dpi.
- ❑ **EPSON high-quality glossy paper.** Use this paper when printing at 720 dpi to produce camera-ready composites. When printing on glossy paper, use only EPSON high-quality glossy paper. For best results, use glossy paper within six months of opening the package.
- ❑ **EPSON transparency film.** When printing transparencies, use only EPSON transparencies. For best results, use transparencies within six months of opening the package. Do not select 720 dpi when printing transparencies.

To order EPSON papers and transparencies, contact your dealer or call EPSON Accessories at **(800) 873-7766** (U.S. only). In Canada, call **(800) BUY-EPSON** for sales locations.

Use the following part numbers when ordering:

Paper	Size	Part Number
Special coated paper for 720 dpi	Letter (8.5 x 11 inches)	S041062
	Legal (8.5 x 14 inches)	S041048
Special coated paper for 360 dpi	Letter (8.5 x 11 inches)	S041060
High-quality glossy paper	Letter (8.5 x 11 inches)	S041072
Transparency film	Letter (8.5 x 11 inches)	S041064

Setting the Paper Thickness and Adjustment Levers

Before you start printing, you should check the paper thickness and thickness adjustment levers to make sure they are set correctly for the type of paper or other media you are loading.

C **Caution:** *Before you change the lever settings, make sure the printer is not loading, printing, or ejecting paper.*

Paper Thickness Lever

The paper thickness lever on the right side of the sheet feeder has two settings: plain paper and thick paper. Set the lever to the position that best suits the paper or other media you plan to use, as shown in the following table and illustration.

Paper type	Paper thickness lever position
Plain or special paper	Plain paper
Transparencies	Plain paper
Envelopes or labels	Thick paper

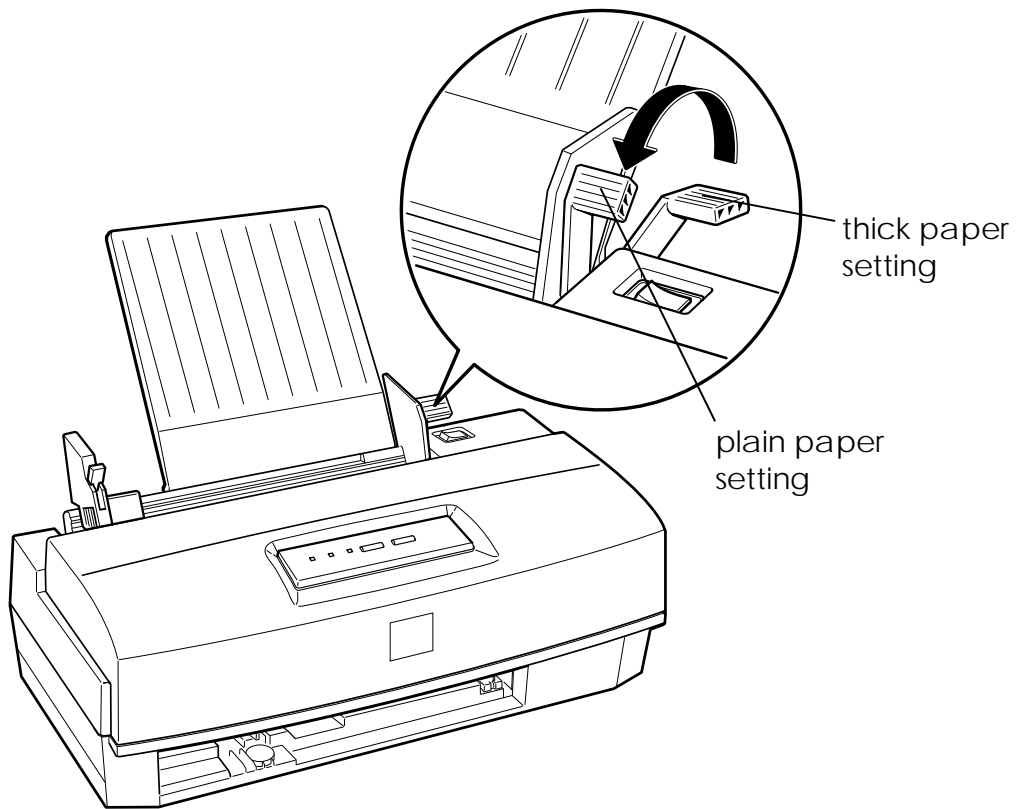

Thickness Adjustment Lever

You need to change the position of the thickness adjustment lever when you print on thick paper—such as envelopes or labels—or if your documents smear, as shown in the following table.

Paper type	Thickness adjustment lever position
Plain or special paper	0
Transparencies	0
Envelopes or labels	+
Previously smeared documents	+

To access the lever, open the printer cover; the lever is in the left back corner, as shown below.

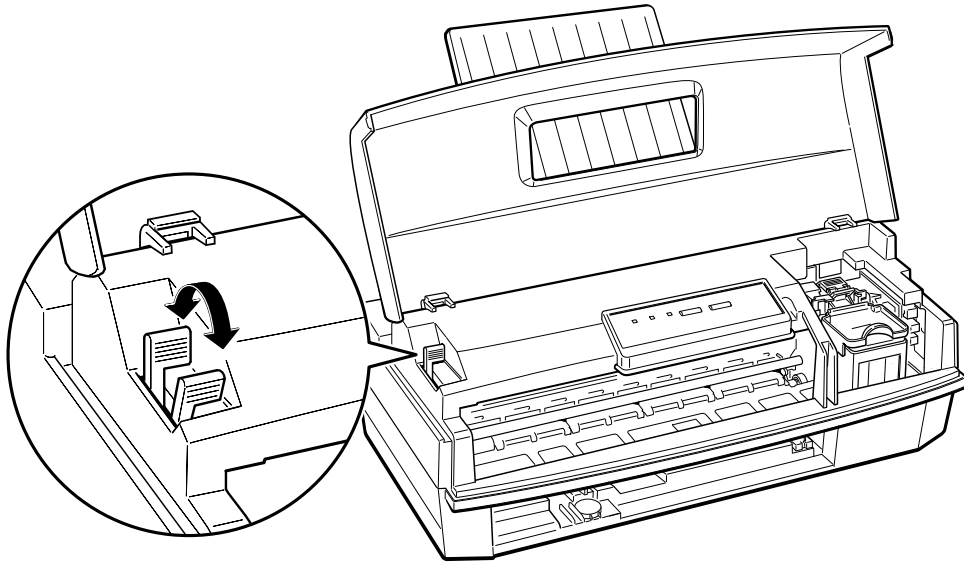

If a document is smeared, set the thickness adjustment lever to the + position (regardless of the paper type) and print it again.

If your document still smears, enable the non-smear printing mode. See “Using the Printer’s Control Panel” in Chapter 4 for more information.

Loading Plain Paper

This section explains how to load plain bond paper in the printer. For instructions on loading coated or glossy paper, envelopes, and transparencies, see page 3-8.

You can load up to 100 sheets of plain paper in the sheet feeder. Be sure to load it with the printable surface facing up. The printable surface is marked with an arrow on most paper packaging.

Note:

You can use these instructions for printing on labels; however, be sure to set the paper thickness lever to the thick paper position and the thickness adjustment lever to the + position. Also make sure no labels are curled or peeling away from the backing when you load them.

1. Push down the left edge guide lock lever; then slide the left edge guide to the left as far as it will go.

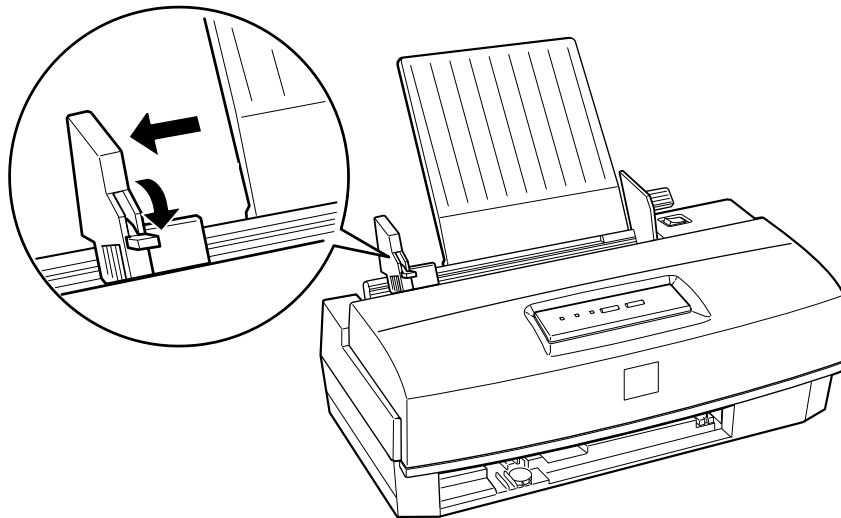

2. Load a stack of paper, printable side up, so that its right edge rests against the right side of the sheet feeder. Do not load paper above the arrow mark inside the left edge guide of the sheet feeder.

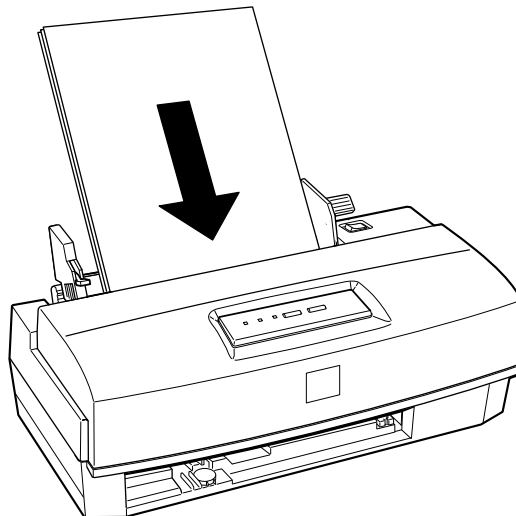

3. Slide the left edge guide against the left edge of the paper; then push up the lock lever to secure its position.

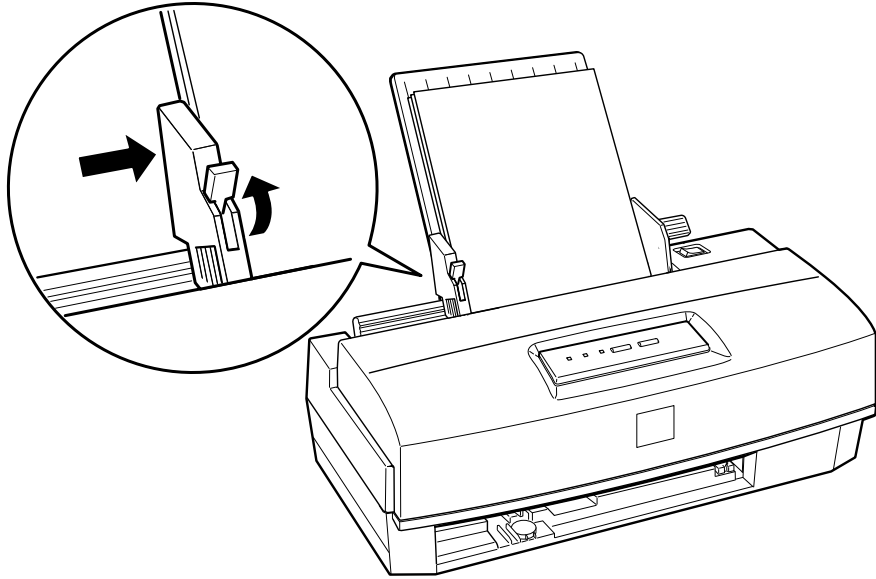

4. Remove the paper, fan the stack, and tap the edges against a flat surface to even it up.
5. Reload the paper straight down into the printer as shown. Then rest it against the paper support.

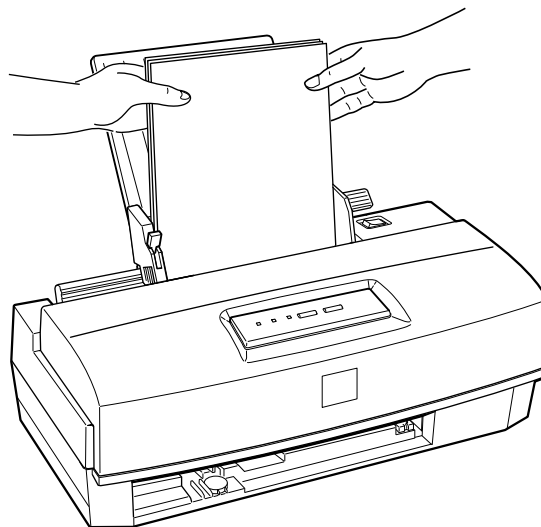

6. Change the Media Type and other printer driver settings so they are appropriate for the paper or labels you loaded. For more information, see Chapter 2. (For labels, select Plain paper as your Media Type.)

Loading Special Papers and Other Media

When using coated paper, glossy paper, envelopes, and transparencies, keep the following in mind:

- ❑ Do not touch the printable surface of the paper; hold the sheets by their edges. The moisture and oils on your hands can reduce print quality.
- ❑ Use special coated paper within one year of purchase. Use glossy papers and transparencies within six months.
- ❑ You can print on sheets of labels in your printer; just follow the instructions for loading plain paper on page 3-5.
- ❑ When printing on high-quality glossy paper or transparencies, remove each sheet from the output tray immediately after it is printed. Make sure each sheet is dry before stacking.
- ❑ Return unused sheets and envelopes to their original package as soon as possible after you finish printing. Unfavorable storage conditions—especially high temperature, humidity, and direct sunlight—can damage the media.
- ❑ Follow any other special loading procedures included in the following sections.

Loading Special Papers and Transparencies

This section explains how to load coated papers, glossy paper, and transparencies. You can load up to the following number of sheets at one time:

- ❑ 70 sheets of special coated paper. If you load legal-size special coated paper for 720 dpi, do not load it more than halfway to the arrow mark on the left edge guide of the sheet feeder.

- ❑ 30 sheets of EPSON high-quality glossy paper with a sheet of plain paper beneath the last sheet in the stack; to avoid printing on the plain paper, print your document one page at a time. If you load a single sheet of glossy paper, place a sheet of plain paper beneath it and print one page at a time.

Note:

If you load multiple sheets of glossy paper, the minimum top margin is 1.2 inches (30 mm). To print with a smaller top margin, load and print glossy paper one sheet at a time.

- ❑ 50 sheets of transparency film, printed one at a time, with one sheet of plain paper beneath the last transparency in the stack.

Follow these steps to load special paper or transparency film:

1. Push down the left edge guide lock lever; then slide the left edge guide to the left as far as it will go.

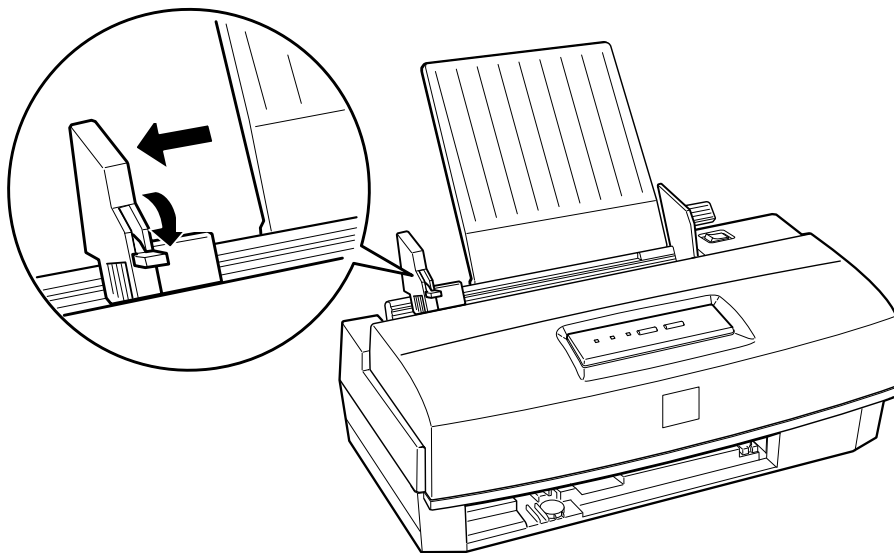

2. Fan a stack of paper or transparencies; then tap it on a flat surface to even the edges.

3. Stack the paper or transparencies so the printable surface faces up. For coated papers, the printable side is whiter than the other side. For glossy paper and transparencies, position the cut corner in the upper right, as shown below.

Load the paper or transparencies straight down into the printer with the printable surface face up; then rest it against the paper support.

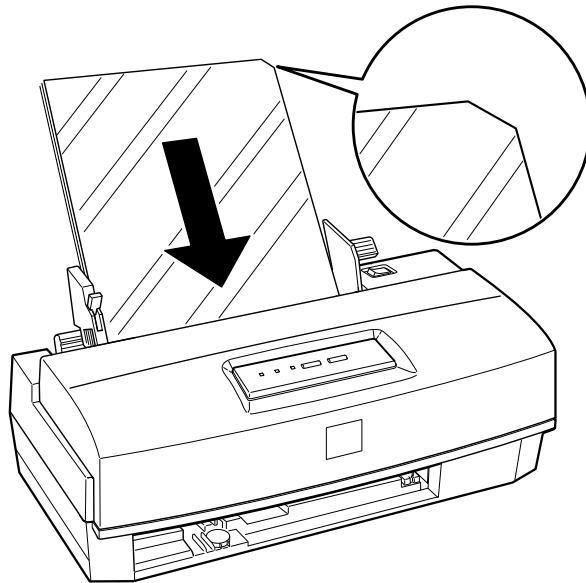

4. Slide the left edge guide against the left edge of the paper; then push up the lock lever to secure its position.
5. Change the Media Type and other printer driver settings so they are appropriate for the paper or transparency film you loaded.

Before printing on EPSON high-quality glossy paper or special coated paper, make sure the color print head unit is installed and Color is selected as the Head Unit setting. For glossy paper, also select Super - 720 dpi for the Printing Mode option. (See Chapter 2 for more information.)

Loading Envelopes

For detailed specifications on the thickness and weight of the envelopes you can load, see Appendix A. Do not use envelopes that are curled or folded, or ones that are too thin; they may curl during printing. Also, do not choose 720 dpi resolution for envelope printing.

Follow these steps to load envelopes:

1. Make sure you set the paper thickness and thickness adjustment levers to the correct positions for envelope printing, as described on page 3-3.
2. Load up to 10 envelopes in the sheet feeder with the front side facing up as shown.

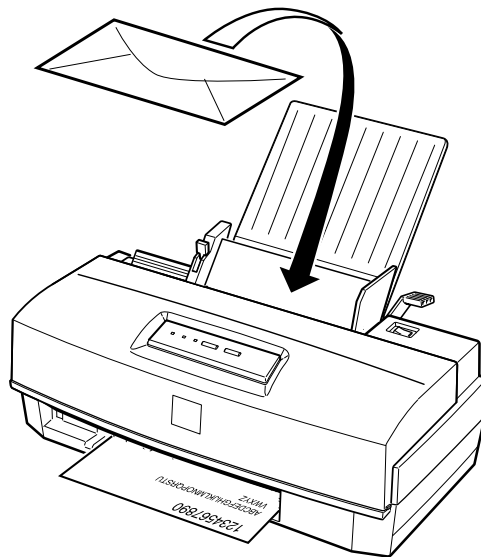

3. Adjust and lock the left edge guide so the envelopes feed straight into the paper path.
4. Change the Paper Size and other printer driver settings so they are appropriate for the envelopes you loaded. (See Chapter 2 for more information.)

Controlling the Printer

Managing Print Jobs	4-2
Using the Printer's Control Panel	4-5
Lights	4-5
Buttons	4-6
Using the Default Setting Mode	4-8

This chapter explains how to control the printer. It is divided into these sections:

- ❑ “Managing Print Jobs” explains how you can use the EPSON Spool Manager, Despooler, and Status Monitor (Windows 95 only) to monitor, cancel, or change the order of print jobs.
- ❑ “Using the Printer’s Control Panel” covers the printer functions available through the control panel on the printer.
- ❑ “Using the Default Setting Mode” describes how to access the printer’s Default setting mode. In rare cases, you may need to use this mode to specify the print direction, use a different character table, or adjust the paper loading position.

Managing Print Jobs

The EPSON Spool Manager was automatically copied to your hard disk drive when you installed the printer software. When you print a document, the printer uses the EPSON Spool Manager to send data to the printer. This allows you to continue working in your software program while printing.

When you send a print job to the printer, the Despooler dialog box appears on your screen and a Spool Manager icon (Windows 3.1) or button (Windows 95) appears near the bottom of your screen. You can also access Spool Manager from the EPSON program group or folder so you can manage print queues or perform other operations when you are not sending a print job. (See Spool Manager’s online help utility for more information.)

Note:

In Windows 3.1, you may not see the Spool Manager icon in the bottom portion of your screen if the Program Manager window or an application window is maximized. Reduce the window size to reveal the icon.

The Despooler is a program with a dialog box, similar to the one shown below, that appears when you send a print job to the printer. It allows you to monitor the progress of the print job and cancel (■), pause (||), or restart (◀◀) the job.



Note:

If you do not want the Despooler dialog box to appear each time you print you can turn it off using Spool Manager. Start Spool Manager, open the View menu, and select Show Despool Popup to turn it off; the checkmark next to the option disappears.

If you're using Windows 95, the Status Monitor box appears inside the Despooler dialog box (as shown above) each time you send a print job. It includes a gauge representing the amount of ink left in the cartridge and an icon that reports the current status of your printer. The icon alerts you to any printer error conditions.

Note:

The Status Monitor appears only if your printer is connected to the host computer; it does not appear when you are printing over a network with the printer connected to another computer.

The Status Monitor uses these icons to report the status of your printer:



Checking the printer status.



A printing error has occurred and your printer cannot print.



The printer is ready to print.



The printer is currently printing.



The ink level is low or empty; check the Ink Out light on the control panel and replace the cartridge.

Note:

If you get an error message while trying to print, the problem may be caused by conflicts with other temporary files or directories. See Chapter 6 for more information.

Using the Printer's Control Panel

The printer's control panel contains lights for displaying the printer status and buttons for controlling certain functions.

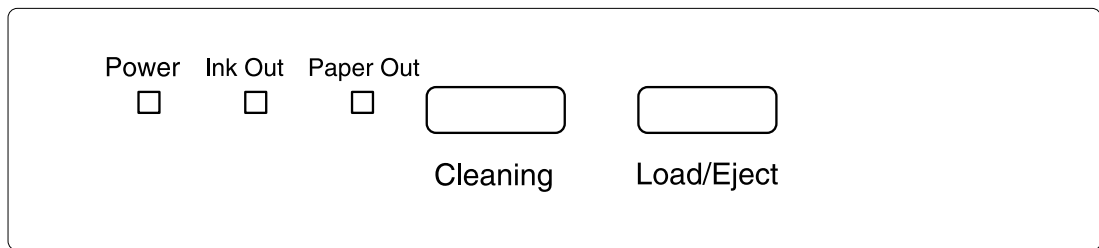

Most printer settings can be controlled from software, so you normally use the control panel only to do the following:

- Clean the black or color print heads
- Replace an ink cartridge or print head unit
- Print a self test or demonstration page.

Lights

Power	On when the printer is on. Flashes while replacing the ink cartridge or print head unit, while cleaning the print head, and in certain error conditions.
Ink Out	Flashes when ink is low or during certain error conditions. On when the ink cartridge is empty or not installed. (The printer will not work when the ink cartridge is empty or not installed.)
Paper Out	On when the printer runs out of paper. Flashes if there is a paper jam or in certain error conditions.

Note:

For a list of error conditions indicated by the control panel lights, see Chapter 6.

Buttons

This section describes the control panel button functions and their functions in power-on sequences.

- Load/Eject Loads or ejects a sheet of paper. (The printer normally loads and ejects paper automatically.) Also used when you replace the ink cartridge or print head unit.
- Cleaning Starts a print head cleaning cycle.

Button functions in power-on sequences

Press these buttons while turning on the printer to perform the functions described. The Ink Out and Paper Out lights flash briefly before the operation begins.

- Cleaning
(Self test) Checks the paper length and performs a printer self test at 360 dpi. (Paper must be loaded in the printer.) Hold down Cleaning until the printer feeds the first page. Then press Load/Eject to print the next page. To stop the self test, wait until the second page prints and then turn off the printer. (See Chapter 1 for more information on testing the printer.)
- Load/Eject
(Demo page) Prints a demonstration page of the printer's fonts and colors. (Paper must be loaded in the printer.) Hold down Load/Eject until the printer feeds a page. To exit demonstration mode, wait until the page prints and then turn off the printer.

Load/Eject then Cleaning (Non-smear mode)

Enables non-smear printing mode, which reduces the chance of smeared pages by decreasing the per-line printing speed. This mode is helpful when printing on coated or glossy paper because it allows more time for the ink to dry.

Hold down Load/Eject as you turn on the printer; then press Cleaning while the Ink Out and Paper Out lights are flashing. Send a print job.

To exit non-smear mode, wait until all pages print and turn off the printer.

Load/Eject and Cleaning (Default setting mode)

Enters the printer's Default setting mode and prints an instruction page; see page 2-8 for more information. (Paper must be loaded in the printer.) Hold down both the Load/Eject and Cleaning buttons while you turn on the printer and hold them down until the printer feeds a page.

To use Default setting mode without printing an instruction page, hold down Load/Eject and Cleaning, and turn on the printer; then press Load/Eject again. To exit the Default setting mode, wait until all pages print and turn off the printer.

Cleaning then Load/Eject (Hex dump mode)

Prints a page containing a hexadecimal representation (hex dump) of the data received by the printer for troubleshooting purposes; see Chapter 6 for more information. (Paper must be loaded in the printer.)

Hold down Cleaning as you turn on the printer; then press Load/Eject while the Ink Out and Paper Out lights are flashing. Send a print job. To exit hex dump mode, wait until all pages print and turn off the printer.

Using the Default Setting Mode

Additional printer functions are available through the Default setting mode. Because the printer's factory default settings are designed to meet the needs of almost all users, you rarely need to change the additional printer functions listed below. If necessary, however, you can turn on Default setting mode and change the settings using the control panel buttons.

- ❑ **Character table.** Selects the set of characters and symbols that can be printed. The default is the Italic U.S.A. character table. If you commonly use a language containing accents, symbols, or other characters not available in the Italic U.S.A. character table, change to a different character table. For a list of available character tables, see Appendix B.
- ❑ **Print direction.** Specifies how the print head moves across the page. The options are Uni-D, Bi-D, and Auto (default). When Uni-D is on, the print head prints in only one direction to provide the most precise alignment for graphics and text. In Bi-D printing, the print head prints in both directions. Bi-D is faster, but the vertical alignment may not be as precise as Uni-D. When Auto is selected, the printer switches automatically between Uni-D and Bi-D as necessary when it receives data.
- ❑ **Network interface mode.** If you're having trouble printing when the printer is connected to multiple computers, turn on network interface mode. By default, network interface mode is off.

- ❑ **Auto line feed.** Specifies that a carriage return character encountered in the print file be accompanied by a line feed command. By default, auto line feed is off. If text lines print on top of one another, turn on auto line feed.
- ❑ **Loading position.** Determines the top margin by defining how close to the paper edge the first line can print. The loading position can be 3 mm or 8.5 mm (default). Normally you should use your software to adjust your top margin.
- ❑ **Font and Pitch.** Select the built-in printer font and character pitch used as the default setting. The factory default pitch is 10 cpi (characters per inch); the default font is `Courier`. Generally you use your software to select the font and pitch.
- ❑ **Thick paper.** Select Envelope (default) if you print on thick paper or envelopes.
- ❑ **Monochrome print speed.** Sets a faster print speed when the monochrome print head unit is installed. The speed can be 167 cps (characters per second) or 125 cps (default).
- ❑ **Economy.** Turns on economy mode for printing rough drafts. With economy mode on, the printer uses less ink by printing fewer dots per character. (The default setting is off.)

To turn on the Default setting mode and print instructions, turn off the printer. Then hold down both the Load/Eject and Cleaning buttons while you turn the printer back on, and keep holding down the buttons until an instruction page prints. Follow the instructions on the page to select a language; then press Load/Eject to print a second instruction page.

Follow the instructions the printer prints to change the default settings by pressing buttons on the control panel. To exit Default setting mode, wait until printing stops and turn off the printer.

Cleaning the Print Head	5-2
Changing the Print Head Unit	5-3
Replacing an Ink Cartridge	5-6
Selecting the Correct Ink Cartridges	5-7
Removing and Installing an Ink Cartridge	5-7
Cleaning the Printer	5-10
Transporting the Printer	5-11
Calibrating the Printer	5-12
Calibrating the Printer From Windows	5-13
Calibrating the Printer From DOS	5-14

The instructions in this chapter tell you how to do the following to maintain and care for your printer:

- ❑ Clean the print head
- ❑ Change the print head unit
- ❑ Replace an ink cartridge
- ❑ Clean the printer
- ❑ Transport the printer
- ❑ Calibrate the printer.

Cleaning the Print Head

The printer periodically cleans the print head for you, so normally you should not need to run a cleaning cycle. However, if print quality diminishes, run the print head cleaning cycle to unclog the print head so the nozzles deliver ink properly.

Follow these steps to clean either print head:

1. Make sure the printer is turned on and not printing.
2. Press the Cleaning button. The cleaning cycle takes about one minute, during which the carriage moves and you hear the printer recharging the print head. The Power light flashes throughout the cycle and then stays on when it is finished.
3. Turn off the printer.
4. Hold down the Load/Eject button as you turn the printer back on. This prints a demonstration page so you can see if your print quality has improved.

5. After the page prints, turn off the printer to exit demonstration mode.

If your print quality has not improved, repeat the steps above. If the quality has not improved after you clean the print heads five times, and you are sure the printer is not low on ink, contact your dealer or authorized EPSON servicer.

To clean the other print head, change the print head unit (as described below) and repeat the steps above.

Changing the Print Head Unit

When you need to switch between color and monochrome printing (or vice-versa), follow the instructions in this section to remove one print head unit and replace it with the other.

C **Caution:**
When you change the print head unit, always leave the ink cartridge installed in it. Once you remove an ink cartridge from its print head unit, it becomes unusable.

1. Make sure the printer is turned on and not printing.
2. Open the printer cover by lifting the edges on both sides.

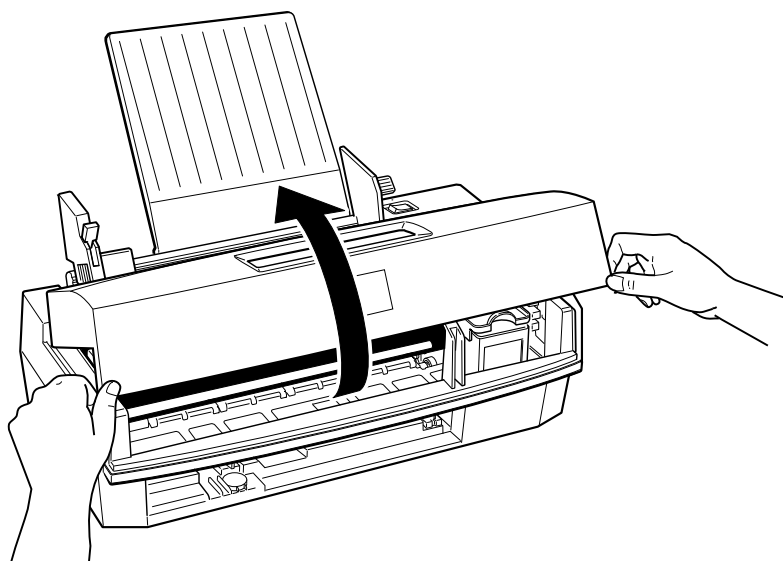

3. Hold down the Load/Eject button for about five seconds until the print head moves slightly left, to the print head unit replacement position. The Power light begins flashing. (The print head unit returns to its home position if you do not perform the operation in step 4 within 60 seconds.)

C **Caution:**
Never move the print head unit by hand; always use the Load/Eject button to move it.

4. Raise the print head unit release lever as far as it will go.

C **Caution:**
Do not lift up the ink cartridge clamp; the ink cartridge and print head will become unusable.

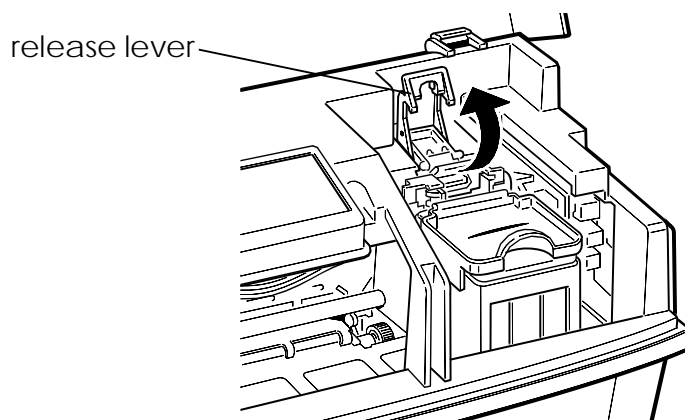

5. Grasp both sides of the print head unit and carefully lift it out of the printer. Place it on a flat, clean surface.

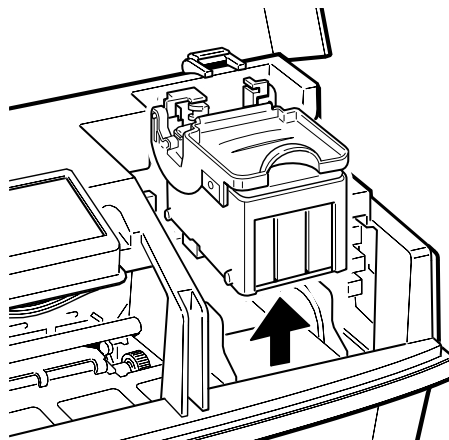

C **Caution:**
Do not touch the electrical contacts on the back and bottom of the print head unit or inside the printer; you may damage them.

6. Remove the other print head unit from its storage box by pressing the notch as shown.

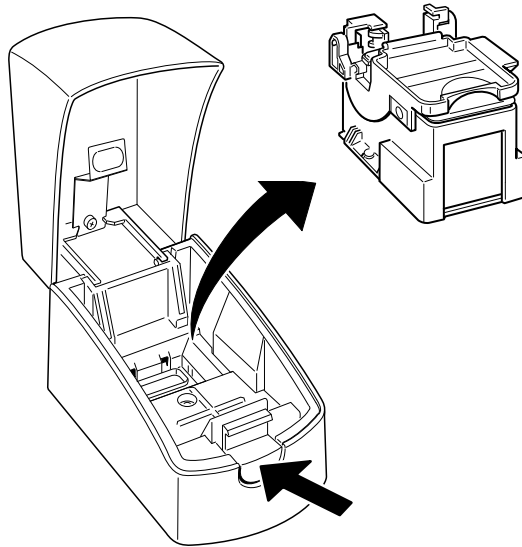

7. Carefully insert the print head unit into the printer with the electrical contacts and the print head facing the back of the printer, as shown.

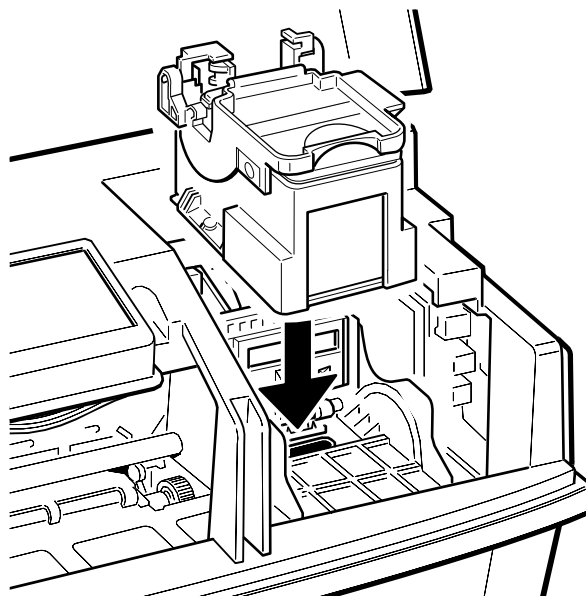

8. Press down the print head unit release lever until it clicks into place.

C **Caution:**
If the Power and Ink Out lights start flashing, remove the print head unit (beginning with step 4) and reinsert it.

9. Press the Load/Eject button to return the print head to its home position. (Even if you do not press Load/Eject, the printer moves the print head back to its home position about 60 seconds after you press down the lever.)
10. Place the print head unit you removed in the storage box. Always store the unused print head unit in this box to protect its delicate components.
11. Close the printer cover.

Replacing an Ink Cartridge

The printer's Ink Out light tells you when an ink cartridge is low on ink and when you need to replace the cartridge. If the Ink Out light flashes, the cartridge is low on ink. If the printer stops and the Ink Out light comes on, the cartridge is empty.

C **Caution:**
Do not replace an ink cartridge unless the Ink Out light tells you to. If you replace a cartridge before the light flashes, the sensor that tells you when ink is out will not work with the new cartridge.

Leave the old cartridge installed in the printer until you are ready to replace it with a new one. Attempting to print without a cartridge installed can damage the printer.

C **Caution:**
When you discard your used ink cartridge, always remove it from the print head unit first; do not discard the print head unit.

Once you install an ink cartridge, do not open the clamp or remove the cartridge except to replace it with a new one. Once you remove a cartridge, you cannot reuse it.

Selecting the Correct Ink Cartridges

Use only these EPSON ink cartridges:

Black ink cartridge	S020047
Color ink cartridge	S020097

When you need new ink cartridges, contact your dealer or call EPSON Accessories at **(800) 873-7766** (U.S. only). In Canada, call **(800) BUY-EPSON** for sales locations.

C **Caution:**
Use only genuine EPSON cartridges and do not refill them. Other products may cause damage not covered by EPSON's warranty.

Removing and Installing an Ink Cartridge

Follow these steps to replace an ink cartridge:

1. Make sure the printer is on and not printing, and the Ink Out light is flashing or turned on.
2. Open the printer cover by lifting the edges on both sides.
3. Hold down the Load/Eject button for about five seconds until the print head moves slightly left, to the ink cartridge install position. The Power light begins flashing.

(The print head unit returns to the home position if you do not proceed to step 4 within 60 seconds.)

C **Caution:**
Never move the print head by hand; always use the Load/Eject button to move it.

4. Raise the ink cartridge clamp to open it. The cartridge rises partially out of the printer.

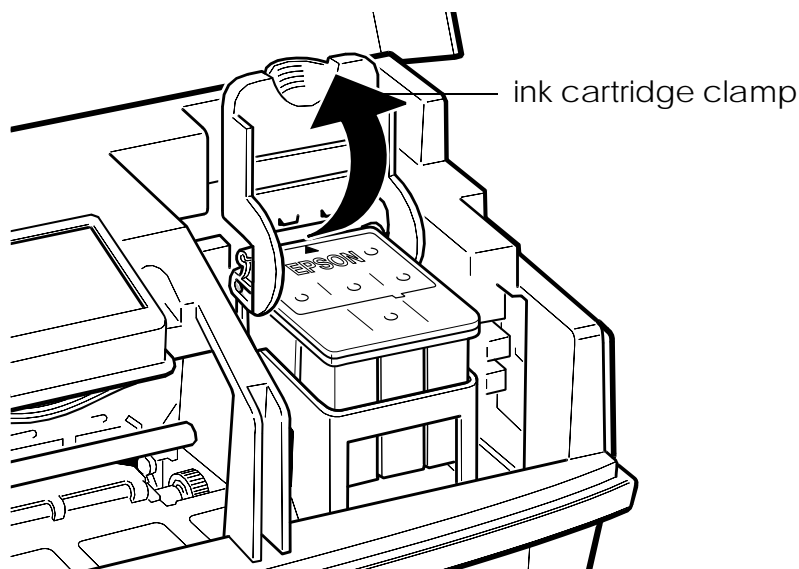

5. Lift the cartridge out of the printer and dispose of it carefully so any excess ink does not spill out. Do not take the used cartridge apart or try to refill it.

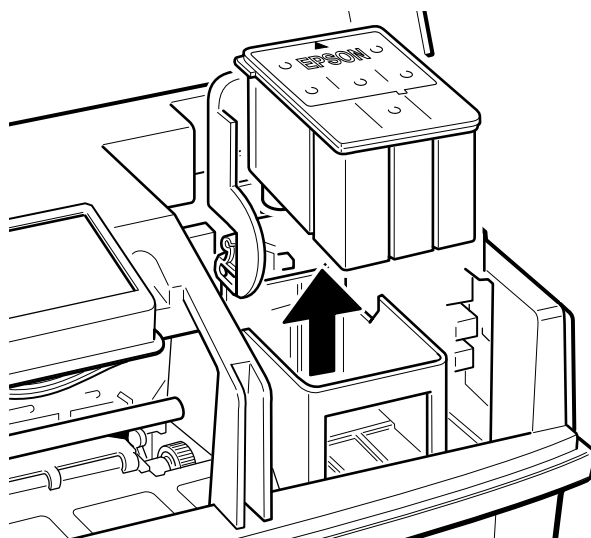

W **Warning:**
If ink gets on your hands, wash them thoroughly with soap and water. If ink gets into your eyes, flush them immediately with water.

6. Open the package containing the ink cartridge and remove the cartridge from its foil wrapper. Remove the tape seal from the top of the cartridge.

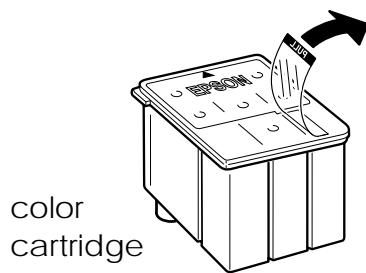

color
cartridge

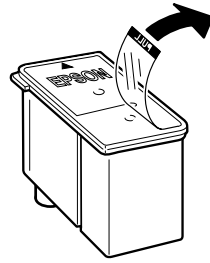

black
cartridge

C **Caution:**
You must remove the tape seal from the top of the cartridge; leaving the tape on will permanently damage it. Do not remove the clear seal from the bottom of the cartridge; ink will leak out.

7. Lower the ink cartridge into the print head unit with the label facing up and the arrow on the top of the cartridge pointing toward the back of the printer.

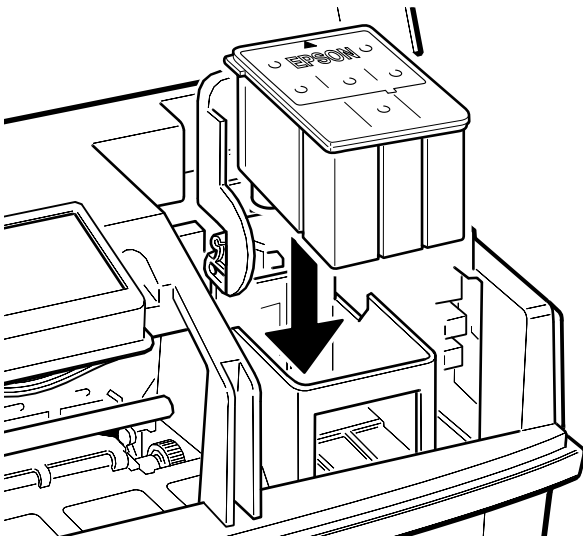

8. Press down the ink cartridge clamp until it locks in place. You will feel some resistance.

C **Caution:**
Once you install an ink cartridge, do not open the ink cartridge clamp again or remove the cartridge except to replace it with a new one. Once you remove a cartridge, do not reuse it; this may damage the print head.

9. Press the Load/Eject button again to return the print head to its home position. (Even if you do not press Load/Eject, the printer moves the print head back to its home position about 60 seconds after you close the clamp.)

The Power light flashes as the printer charges the ink delivery system for about two minutes.

10. Close the printer cover. When the charging cycle finishes, the Power light stops flashing and stays on.

C **Caution:**
Never turn off the printer while the Power light is flashing.

Cleaning the Printer

If you want to clean the printer, follow these steps:

1. Turn off the printer and disconnect any cables connected to it. Be sure to keep the printer cover closed as you clean it.
2. Remove any paper or other media from the sheet feeder.
3. Carefully clean away loose dust and dirt with a soft brush or cloth.
4. Clean the exterior of the printer with a soft cloth dampened with mild detergent.

5. To clean ink out of the printer's interior, wipe it gently with a damp cloth.

C **Caution:**
Never use alcohol or thinner to clean the printer; these chemicals can damage the components and the printer case.

Do not use a hard or abrasive brush; these can scratch the printer surfaces.

Do not allow water to get on the printer mechanism or any electronic components.

Do not touch the gears inside the printer.

Do not spray inside the printer with lubricants or oils; they can damage the printer mechanisms.

Do not clean or remove the print head unit while cleaning the printer and do not clean the spare print head unit.

Transporting the Printer

If you need to transport your printer, carefully repack it in the original box and packing materials as follows:

1. Turn off the printer, if you have not already done so.
2. Open the printer cover and make sure that the print head is locked in the far right position. If it isn't, turn on the printer, wait about 10 seconds, and turn it off.

C **Caution:**
Do not remove the ink cartridges when transporting the printer. Transporting the printer without the cartridges installed can damage the printer.

3. Unplug the power cord from the electrical outlet.
4. Disconnect the interface cable from the printer.
5. Use a strong adhesive tape to secure the print head to the side of the printer.
6. Remove any paper from the sheet feeder and remove the paper support.
7. Attach the protective materials to the printer. See the Notice Sheet that was packed with the printer.
8. Repack the printer and attachments in the original box.

Be sure to keep the printer flat as you transport it. If you notice problems with printed output after transporting the printer, clean the print head as described on page 5-2. If the printed image is misaligned, calibrate the printer as described below.

Calibrating the Printer

Your printer has been calibrated at the factory so that vertical lines in your text and graphics are properly aligned. If you notice misaligned images in printouts, however, you can calibrate the printer with the EPSON Printer Calibration Utility. You may need to do this after moving the printer to a new location, for example.

You can calibrate your printer from Windows or from DOS. To use the Windows utility, see the next section. To calibrate from DOS see page 5-14.

Calibrating the Printer From Windows

Before calibrating, load several sheets of paper in your printer. Then follow these steps:

1. In Windows, double-click EPSON Printer Calibration in the EPSON program group or folder.
2. At the first screen, click OK.
3. Make sure Stylus Color200 is selected in the drop-down menu.
4. Click the Black or Color radio button to select the print head installed in the printer. Then click Next.
5. At the next screen, select the port to which you connected your printer and click Next.
6. Make sure the printer is loaded with several sheets of letter-size paper. Then click Next.
7. The printer prints the Current Alignment Sheets. Examine the printout for misaligned vertical lines.

|
|
Aligned

|
|
Not aligned

If none are misaligned, click Next and go to step 11.

If one or more patterns are misaligned, click the appropriate checkboxes and click Next.

8. Click Next.

9. For each pattern you selected, the printer prints a Test Alignment Sheet containing multiple samples of vertical lines, each of which is assigned a number. On each sheet, look for the sample that is most closely aligned. Then enter the number of the aligned sample or select Not-aligned if none of the samples are aligned. Click Next.
10. Repeat steps 8 and 9 until all patterns are aligned.
11. Click the Print Current Alignment Sheet checkbox to print a final test sheet or click Finish to exit the Calibration Utility.

Calibrating the Printer From DOS

Before you calibrate the printer from DOS for the first time, you must copy the EPSON Printer Calibration Utility to your computer's hard disk.

Copying the calibration utility

1. Insert the EPSON Setup disk 1 into your diskette drive.
2. At the DOS prompt, type A:SETUP (or B:SETUP if you inserted the diskette in drive B) and press Enter.
3. When you see the Printer Utility Setup screen, highlight Epson Stylus COLOR 200 and press Enter.
4. At the next screen, select the directory in which you want to install the calibration utility. To choose the default directory (C:\CALIBRAT), press Enter; to change the directory, erase the default, type in another, and press Enter.
5. Follow the prompts on the screen to install the software.
6. At the installation completion prompt, press Enter.

Running the calibration utility

Before you run the calibration utility, load several sheets of letter-size paper in the printer. You can use the utility with a keyboard or a mouse (keyboard instructions are given below).

1. Log onto the directory to which you copied the calibration utility.
2. At the DOS prompt, type ECALIB and press Enter to run the calibration utility. You see the EPSON Printer Calibration Utility screen.
3. Make sure Stylus Color 200 is selected in the drop-down menu. If not, press ↓ or ↑ to highlight it.
4. Press Tab to move to the Calibration item box and select the print head you have installed in the printer: color or black (monochrome).
5. Press Tab twice to highlight the Next button and press Enter.
6. At the next screen, select the port to which you connected the printer and select Next.
7. Select Next at the next screen if you've already loaded paper.
8. The printer prints the Current Alignment Sheet. Examine the printout for misaligned vertical lines.



Aligned



Not aligned

If none are misaligned, press Tab twice to highlight Next and press Enter. Go to step 13.

If one or more patterns are misaligned, select the appropriate checkboxes; then select Next.

9. Select Next.
10. For each pattern you selected, the printer prints a Test Alignment Sheet containing multiple samples of vertical lines, each of which is assigned a number. On each sheet, look for the sample that is most closely aligned.

Enter the number of the aligned sample or select Not-aligned if none of the samples are aligned. Then select Next.

11. Repeat steps 9 and 10 until all patterns are aligned.
12. Select the Print Current Alignment Sheet checkbox to print a final test sheet or select Finish to exit the Calibration Utility.

Troubleshooting

Diagnosing Problems 6-2

Print Quality Problems 6-3

Problems With Printing 6-8

Paper Handling Problems 6-13

 Paper Jam Problems 6-13

 Paper Feeding Problems 6-14

 Other Paper Handling Problems 6-14



This chapter describes what you can do if you are having problems printing. It is divided into these sections:

- ❑ **Diagnosing problems.** See this section to diagnose problems by checking the control panel lights and Status Monitor icons (Windows 95 only).
- ❑ **Print quality problems.** See this section if the print quality is not good or not what you expect.
- ❑ **Problems with printing.** See this section if your printer is having trouble printing.
- ❑ **Paper handling problems.** See this section if you have paper jams or other problems with paper handling.





Diagnosing Problems

Your printer's control panel and the Status Monitor box in the EPSON Despooler (Windows 95 only) report the status of your print job and alert you to printing errors. Check the tables below to diagnose your problem using the control panel lights and the Status Monitor icons.

Control panel light status

Problem	Ink Out	Paper Out
Ink low	Flashing	Off
Ink out	On	Off
Paper out	Off	On
Paper jammed	Off	Flashing
Print head unit or ink cartridge installation error	Rapid flashing	Off
Carriage error	On	On
Fatal error	Flashing	Flashing

Status Monitor icon status

Icon	Problem
	The printer is checking the current status.
	A printing error has occurred and your printer cannot print. See "Problems With Printing" in this chapter for possible solutions.
	The printer is ready to print.
	The printer is currently printing.
	The ink level is low; check the Ink Out light and replace your ink cartridge as described in Chapter 5.

Note:

In Windows 95, if the Status Monitor box does not appear with the Despooler when you print, see page 6-11.

If you have a printing problem, check the appropriate section below and follow all suggestions that apply to your problem. Also check the ReadMe item in the EPSON program group or folder and the online help available in the driver for the latest information. If none of the suggested solutions solve your problem, see "Where to Get Help" in the Introduction.

Print Quality Problems

To help you determine the nature of a print quality problem, you may want to print a demonstration page and analyze the elements on it; see Chapter 4 for instructions. Print quality can often be improved by cleaning the print head as described in Chapter 5.

If cleaning the print head does not improve the print quality, try the following:

- ❑ Check the status of the Ink Out light to see whether the ink cartridge is low on ink or empty. If so, replace the cartridge as described in Chapter 5.
- ❑ For color or complex grayscale images, turn on MicroWeave and turn off High Speed mode.
- ❑ Use a higher quality paper. For best print quality, use EPSON special coated papers for 360 and 720 dpi or EPSON high-quality glossy paper (720 dpi only).

Note:

Do not use high-quality glossy paper when you print at 360 dpi.

- ❑ Make sure the Media Type setting matches the type of paper or other media loaded in the printer.
- ❑ If you're printing a scanned image and the colors are not right, first try to fix the problem using your scanning software program.

If print quality does not improve, see the following specific problems.

Printed output is not what you expect, or is faint or blurred.

You may not be printing on the correct side of the paper. On coated paper, print only on the white coated side; on glossy paper or transparencies, print only with the cut corner in the upper right. Also remove each sheet as it is printed to prevent smearing by the next sheet.

Check that the paper thickness and thickness adjustment levers are set correctly for the media type. (See Chapter 3 for more information.) Faint or blurred printouts can result if you print with these levers in incorrect positions.

Use a higher quality paper. Also, check that the Media Type setting in the driver is set for the type of paper or other media you loaded. If you are using the 720 dpi printing mode, you get better results if you use EPSON special coated paper for 720 dpi or EPSON high-quality glossy paper.

You may be printing on special coated or glossy paper at 360 dpi with the monochrome print head unit. For better results, print on plain paper or transparencies or use the color head unit and print using composite black.

Check whether your paper is moist or damp. Ink jet printers are sensitive to moisture absorbed by paper. Do not store paper in damp or humid places.

If you are printing color graphics at 360 or 720 dpi, make sure MicroWeave is on and High Speed mode is off. Also check that the Brightness and Contrast settings are appropriate for the image.

Turn on non-smear printing mode, if necessary, as described in Chapter 4.

Make sure the correct print head unit is selected in the printer driver. Select Color for the color print head and Mono for monochrome print head.

Try using the printer driver's Auto Document Type feature to let the driver determine the appropriate image settings.

Your Windows video driver may not be compatible with the printer. Use the standard Windows VGA driver or contact the manufacturer of your video card for an updated driver. For information on changing the video driver, see your Windows documentation.

Clean the print head as described in Chapter 5.

Replace the ink cartridge as described in Chapter 5.

Vertical lines do not align.

Calibrate your printer as described in Chapter 5.

You see white banding in your printed output.

Turn on MicroWeave in the printer driver. If you still see white banding, clean the print head as described in Chapter 5.

Print speed is not what you expect.

You may be printing a text document using printer driver settings that are more appropriate for graphics. Select the Economy Document Type for the fastest text printing settings.

Print speed is slower for large documents and for those printing at high resolution. Experiment with smaller file sizes and lower resolutions to speed up printing. If this is not possible, be patient; the printed results will be worth the wait.

The printout contains incorrect or garbled characters.

Make sure EPSON Stylus COLOR 200 is selected as the default Windows printer driver.

If you are running Windows, make sure the Print Manager is turned off in the Control Panel Printers utility; see your Windows documentation or online help for instructions.

Print jobs may be held in the EPSON Spool Manager. Click Spool Manager 3 in the EPSON program group or folder. Select any print jobs marked pending, waiting, or held; then select Delete or Cancel Printing.

If you still see incorrect characters, print a demonstration page to see if the problem is with your printer; see Chapter 4 for instructions. If the demonstration page prints, you may have a problem with your application software or your printer cable. Make sure your cable is connected securely and see your program's documentation for troubleshooting information.

If no demonstration page prints, you may have a problem with your printer; contact your EPSON dealer or authorized EPSON servicer.

You see incorrect colors in your printout.

Make sure EPSON Stylus COLOR 200 is selected as the default Windows printer driver.

Check that the printer driver's Brightness, Contrast, Saturation, and Red, Green, and Blue Strength settings are appropriate for the image.

If you scanned the image, the different color interpretation technologies used by your scanner, monitor, and printer can never produce an exact color match with the original image. However, check your scanner documentation for utilities you can use to calibrate your scanner to your monitor and printer to more closely match colors.

If you are printing from a DOS application using economy mode, black text or graphics will appear gray on your printout; turn off economy mode using the printer's Default setting mode to achieve deeper blacks. See Chapter 4 for instructions.

Printing starts too high or too low on the page, or the page length or margins are not what you expect.

Make sure you selected the correct Paper Size setting in the printer driver; see Chapter 2 and your online driver help utility for more information.

Use your software program to adjust the margins, or change the number of lines per page, or change the page length setting to match the paper you are using.

If necessary, change the loading position of the paper using the Default setting mode as described in Chapter 4.

Problems With Printing

If you cannot get the printer to print, first check that paper is loaded in the printer. Then check that the printer is plugged into a working electrical outlet that is not controlled by a switch or timer. Verify that the interface cable is securely connected to the printer and computer and that both are turned on.

After you have done all this, see the following specific problems.

Printing stops and the Paper Out light is on.

No paper is loaded in the printer or it is loaded incorrectly. Load paper in the sheet feeder correctly; then press the Load/Eject button to turn the Paper Out light off and resume printing.

Printing stops and the Paper Out light is flashing.

Paper may have jammed in the printer. Turn off the printer and gently pull out the paper. If it tears off inside the printer, open the printer cover and remove the paper. See “Paper Handling Problems” later in this chapter for information on preventing paper jams.

The Ink Out light is flashing or on.

If the Ink Out light is flashing, the ink cartridge is low on ink; if it is on, the cartridge is empty. Replace the ink cartridge as described in Chapter 5.

The Ink Out light flashes rapidly.

You may have pressed the Load/Eject button when the ink cartridge or the print head unit was not installed or not installed correctly. Follow the steps in Chapter 5 to install the ink cartridge or reinstall the print head unit.

Printing stops and the Ink Out and Paper Out lights are on.

There is a carriage error. Turn off the printer; then, after a few seconds, turn it on and try printing again. If the same lights flash again, contact your dealer or an authorized EPSON servicer.

Printing stops and all lights are flashing.

There is a fatal error; contact your dealer or an authorized EPSON servicer.

The printer sounds like it is printing, but nothing prints.

The print head may need cleaning; see Chapter 5 for instructions.

The ink cartridge may be too old. A cartridge is too old if it has been used longer than six months or beyond the date on its packaging. First clean the print head as described in Chapter 5. If this does not solve the problem, replace the ink cartridge.

The cable between the printer and computer may not be connected securely or it may not meet the specifications for the printer or computer. See “System Requirements” in Chapter 1 for cable guidelines.

Turn off the printer and perform a self test as described in Chapter 1. If the self test does not print, the problem is with the printer. If the self test prints correctly, the problem is probably caused by your software.

The printer driver installed with Windows 3.1 does not work correctly after you upgrade to Windows 95.

You need to reinstall the printer driver after upgrading to Windows 95 so the driver is set up correctly for Windows 95. See Chapter 2 for instructions.

You see error messages because of printing conflicts.

Before sending print jobs to the printer, the EPSON Spool Manager stores them in a temporary directory. If you see conflict error messages or printing is very slow, the problem may be caused by other temporary files in this directory. To change the Spool Manager default directory, follow these steps:

1. Make a directory on your hard disk where you want Spool Manager to store the files, for example, C:\SPLTEMP.
2. Open the EPSON program group or folder and double-click Spool Manager3.
3. Make sure Epson Stylus COLOR 200 is selected, and then open the Queue menu.
4. Select Setup. In the Queue Setup dialog box, change the spool directory to the one you created in step 1.
5. Also make sure the Use Print Manager for this port checkbox is checked. Then select OK.
6. Open the Options menu and select Default Spool Directory.
7. In the dialog box, change the spool directory to the one you created in step 1. Then select OK.
8. Close the Spool Manager.

The printer prints blank pages.

Make sure EPSON Stylus COLOR 200 is selected as the default Windows printer driver.

Make sure you selected the correct Paper Size setting in the printer driver; see Chapter 2 and your driver's online help utility for more information. Also make sure the margins in your application software fit the paper size you're using.

Text printing is slow.

You may be using printer driver settings that are more suitable for graphics printing and unnecessarily slowing down text printing. If you're printing black text only, make sure the monochrome print head unit is installed in your printer and selected in the printer driver.

To speed up text printing only, turn off MicroWeave mode and turn on High Speed mode. Some combinations of Printing Mode (resolution) and Media Type do not allow you to select these settings; if this is the case for your settings, select a lower resolution, possibly using Economy (180 dpi) for drafts and 360 dpi for your final output. However, do not turn off MicroWeave when printing final copies of high-quality graphics or photographs.

Ink cartridges do not last as long as expected.

The ink cartridge life depends on the amount of ink used in printing. If you often print pages with large graphics and little white space, you will use up cartridges faster than if you print pages with lots of white space. (The printer also uses ink during print head cleaning cycles, so do not perform them unless necessary.)

If you replace an ink cartridge before the Ink Out light flashes, the sensor that tells you when ink is out will not work correctly with the new cartridge.

In Windows 95, the Status Monitor box does not appear with the Despooler.

The Windows Print Manager may be interfering with the Status Monitor. Double-click Spool Manager3 in the EPSON folder. Open the Queue menu and select Setup. Make sure the Use Print Manager for this port checkbox is not checked.

Then check your bidirectional spool settings. Click Start, point to Settings, and select Printers. Double-click the EPSON Stylus COLOR 200 icon, open the Printer menu, and select Properties. Click the Details tab, select Spool Settings, and make sure the Enable bi-directional support for this printer option is turned on. Click OK. The Status Monitor should now appear when you send your next print job.

The printer does not seem to receive print jobs sent by the computer.

Double-click Spool Manager³ in the EPSON program group or folder; then click any job marked pending or held. Open the Document menu and select Delete. To verify that the print queue is not held, open the Queue menu and click Hold if there is a checkmark beside the option. Also change the Spool Manager default directory as described on page 6-10.

Make sure EPSON Stylus COLOR 200 is selected as the default Windows printer driver.

If you still get no output, try printing a demonstration page to see if the problem is with your printer; see Chapter 4 for instructions. If no demonstration page prints, you may have a problem with your printer; contact your EPSON dealer or authorized EPSON servicer.

If the demonstration page prints, you may have a problem with your application software or your printer cable. Make sure your cable is connected securely and see your program's documentation for troubleshooting information.

You can use the printer's hex dump mode to pinpoint communication problems between the printer and a software program. To turn on hex dump mode, first turn off the printer. Then hold down the Cleaning button as you turn on the printer. Keep holding down Cleaning and press Load/Eject. Then send a print job. The printer prints the exact codes it receives from the computer in hexadecimal format. Report the codes to your support technician.

Paper Handling Problems

To prevent paper jams and other feeding problems, try these suggestions.

Paper Jam Problems

Use a higher quality paper that is suitable for ink jet printers and is not too thin, too thick, or rough. For best quality, use EPSON special coated and high-quality glossy papers. See Appendix A for paper specifications.

Do not load too many sheets at once. You can load up to 100 sheets of plain paper, 70 sheets of special coated paper, 50 sheets of transparency film (with one sheet of plain paper beneath the stack), 30 sheets of high-quality glossy paper (with one sheet of plain paper beneath the stack), or 10 envelopes.

Fan the stack of paper before you load it.

If you loaded plain paper, try turning the stack over. The printable side may have been facing down.

Paper Feeding Problems

The paper may be curled or folded. Use flat, undamaged paper.

The paper may be poor quality; use a better quality paper.

The paper may be too thin or thick; see Appendix A for paper size and type specifications.

The paper may have been exposed to excess humidity (over 60%); see Appendix A for the required environmental conditions.

The edge guides may be too tight or too loose. Adjust the left edge guide for the size of the paper and lock it in place.

Too many sheets may be loaded in the sheet feeder. You can load up to 100 sheets of plain paper, 70 sheets of special coated paper, 50 sheets of transparency film (with one sheet of plain paper beneath the stack), 30 sheets of high-quality glossy paper (with one sheet of plain paper beneath the stack), or 10 envelopes.

The paper may be pushed down too far in the sheet feeder. Remove the paper, fan it, even up the stack, and then reload it as described in Chapter 3.

Other Paper Handling Problems

For other paper handling problems, try these suggestions.

The printer loads more than one sheet at a time.

Remove the stack of paper, fan it, and even up the edges. Then reload the paper as described in Chapter 3.

The paper may be too thin or thick, or was exposed to excess humidity; see Appendix A for exact specifications.

Make sure the paper thickness and thickness adjustment levers are set correctly for your media type; see Chapter 3 for instructions.

Make sure the printer driver's Copies setting and the copies setting in your application software are set to print one copy at a time. Also verify that you have selected the correct paper size in the driver and in your application software.

Ejected paper is wrinkled.

The paper may be too thin or damp. Do not store paper in damp or humid places.

Paper does not fully eject.

Use the Load/Eject button to eject the page.

The paper may be too long. Use paper that is within the maximum size listed in Appendix A.

Paper is feeding crooked.

The paper is old or creased. Use only new, smooth sheets of paper.

Too much paper is loaded in the sheet feeder. Remove a few sheets.

The paper is not the proper size and quality; see Appendix A for exact specifications.

Technical Specifications

Printing A-2

Paper A-3

Ink Cartridges A-6

Mechanical A-7

Electrical A-7

Environmental A-8

Safety Approvals A-8

Fonts A-8

Parallel Interface Specifications A-9

 Pin Assignments A-9

 Reverse Channel A-11

 Timing Chart A-14

Initialization A-14

 Default Settings A-15



Printing

Printing method: On-demand ink jet

Nozzle configuration: Monochrome print head: 64 monochrome (black) nozzles (16 × 4 staggered)
Color print head: 60 color nozzles (20 × 3; cyan, magenta, yellow)

Printable columns and printing speed:*

Character pitch (characters per inch)	Printable columns	Printing speed		
		Monochrome		Color
		Normal	Economy	
10	80	125	167	200
12	96	150	200	240
15	120	188	250	300
17 (10 condensed)	136	214	285	342
20 (12 condensed)	160	250	333	400

* Print speeds (in characters per second) are estimated for color printing on letter-size paper and vary depending on system configuration, software application, resolution, and amount of page covered.

Resolution: Maximum 360 dpi raster on a 720 × 720 dpi matrix. Dots are printed in an alternating pattern in which horizontal and vertical dots are non-contiguous. Contiguous printing of dots is available only on the diagonal, which yields an effective resolution greater than 360 dpi.

Paper feed speed: 102 milliseconds per 1/6-inch line

Input buffer: 2.5KB to 15KB depending on monochrome or color print head unit selection

Print direction: Bidirectional with logic seeking for text and graphics; unidirectional and autodirectional modes available in Default setting mode

Control code: ESC/P 2 and expanded raster graphics code

Paper feeding: Auto sheet feeder

Line spacing:	1/6-inch, programmable in 1/360-inch increments
Character tables:	1 Italic and 8 graphics character tables
Character sets:	14 International and 1 legal character sets

Paper

Note:

Since the quality of any particular brand or type of paper may be changed by the manufacturer at any time, EPSON cannot guarantee the use of any particular brand or type of paper. Always test samples of paper stock before purchasing large quantities or printing large jobs.

Paper path:	Sheet feeder, top entry
Sheet feeder capacity:	100 sheets of plain paper at 17 lb (64 g/m ²) 70 sheets of EPSON special coated paper 30 sheets of EPSON high-quality glossy paper with one sheet of plain paper beneath the stack or single sheet loaded and printed one page at a time 50 transparency films with one sheet of plain paper beneath the stack and printed one page at a time 10 envelopes
Paper size:	Letter (8.5 × 11 inches) A4 (210 × 297 mm) B5 (176 × 250 mm) Legal (8.5 × 14 inches) Statement (8.5 × 5.5 inches) Executive (7.5 × 10 inches)
Paper types:	Plain paper and special papers distributed by EPSON (high-quality glossy paper, special coated paper, and transparencies)
Paper thickness:	0.003 to 0.004 inch (0.08 to 0.11 mm)
Paper weight:	17 to 24 lb (64 to 90 g/m ²); use 24 lb (90 g/m ²) paper under normal temperature and humidity conditions.

Envelopes:

Size	No. 10	9.5 × 4.1 inches (240 × 104 mm)
	DL	8.7 × 4.3 inches (220 × 110 mm)
Paper types	Plain, bond, or airmail paper	
Paper thickness	0.006 to 0.02 inch (0.16 mm to 0.52 mm)	
Paper weight	12 to 24 lb (45 to 90 g/m ²)	

Transparencies:

Size	A4	(210 × 297 mm)
	Letter	(8.5 × 11 inches)
Thickness	0.003 to 0.0033 inch (0.075 to 0.085 mm)	

Note:

Poor quality paper may reduce print quality and cause paper jams and other problems. If you encounter problems, switch to a higher grade of paper.

Print on special coated paper, high-quality glossy paper, envelopes, and transparencies only under these conditions:

Temperature: 59 to 77°F (15 to 25°C)

Humidity: 40 to 60% RH

(High-quality glossy paper can be stored at 20 to 60% relative humidity.)

Do not load curled or folded paper, envelopes, or transparencies.

The following EPSON genuine papers are available:

<i>Special coated paper for 720 dpi printing (Letter)</i>	<i>S041062</i>
<i>Special coated paper for 720 dpi printing (Legal)</i>	<i>S041048</i>
<i>Special coated paper for 360 dpi printing (Letter)</i>	<i>S041060</i>
<i>High-quality glossy paper (Letter)</i>	<i>S041072</i>
<i>Transparency film (Letter)</i>	<i>S041064</i>

Printable area:

Single sheets

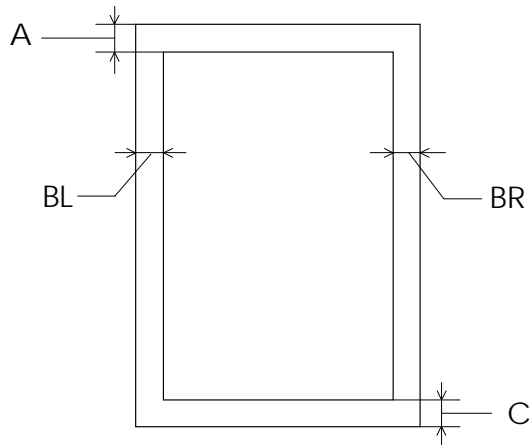

Envelopes

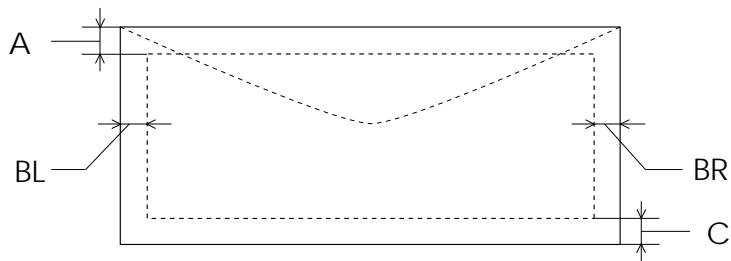

A The minimum top margin is 0.12 inch (3.0 mm).

Note: When printing multiple sheets of glossy paper, the minimum top margin is 1.2 inches (30 mm).

BL The minimum left margin is 0.12 inch (3.0 mm).

BR The minimum right margin is:

0.12 inch (3.0 mm) for Statement and Executive paper

0.38 inch (9.7 mm) for Letter and Legal paper, and transparencies

0.15 inch (3.8 mm) for A4 paper

0.54 inch (13.8 mm) for DL envelopes

1.38 inches (35.1 mm) for #10 envelopes

C The minimum bottom margin is 0.54 inch (14.0 mm).

Note:

Always load paper into the sheet feeder short edge first except envelopes. Load envelopes long edge first.

Ink Cartridges

Black ink cartridge (S020047):

Color	Black
Print capacity*	540 pages (A4 paper; text)
Cartridge life	2 years from production date and up to 6 months after opening the package at 77°F (25°C).
Temperature	Storage: -22 to 104°F (-30 to 40°C) 1 month at 104°F (40°C) Transit: -22 to 140°F (-30 to 60°C) 1 month at 104°F (40°C) 120 hours at 140°F (60°C) Freezing:** 26.6°F (-3°C)
Dimensions	1.3 inches (W) × 2.3 inches (D) × 1.7 inches (H) 33 mm (W) × 58 mm (D) × 43.2 mm (H)

Color ink cartridge (S020097):

Colors	Cyan, magenta, and yellow
Print capacity*	320 pages (A4 paper; 360 dpi; 5% each color)
Cartridge life	2 years from production date and up to 6 months after opening the package at 77°F (25°C).
Temperature	Storage: -22 to 104° F (-30 to 40°C) 1 month at 104°F (40°C) Transit: -22 to 140°F (-30 to 60°C) 1 month at 104°F (40°C) 120 hours at 140°F (60°C) Freezing:** 21.2°F (-6°C)
Dimensions	1.8 inches (W) × 2.2 inches (D) × 1.7 inches (H) 45.9 mm (W) × 56.5 mm (D) × 43.2 mm (H)

* The print capacity may vary depending on how often you use the print head cleaning function. Also, if you print large graphics and dense text with little white space, you use ink faster.

** The ink thaws and is usable after approximately 3 hours at 77°F (25°C).

C Caution:
Use only genuine EPSON cartridges and do not refill them. Other products may cause damage not covered by EPSON's warranty.

Do not use an ink cartridge after the expiration date on the package.

Mechanical

Paper feed method:	Friction with auto/manual sheet feeder, top entry
Total print volume:	25,000 pages
Dimensions:	Without paper support Width: 15.6 inches (396.7 mm) Depth: 8.1 inches (205.6 mm) Height: 5.7 inches (144.0 mm) With paper support Width: 15.6 inches (396.7 mm) Depth: 8.1 inches (205.6 mm) Height: 10.5 inches (267.3 mm)
Weight:	8.6 lb (3.9 kg) without the ink cartridge and print head unit

Electrical

Input voltage range:	103.5 to 132 V
Rated frequency range:	50 to 60 Hz
Input frequency range:	49.5 to 60.5 Hz
Rated current:	0.5A
Power consumption:	Approx. 15 W (ISO 10561 letter pattern)

Environmental

Temperature:	Operation	50 to 95°F (10 to 35°C)
	Storage*	-4 to 140°F (-20 to 60°C) 1 month at 104°F (40°C) 120 hours at 140°F (60°C)
Humidity:	Operation	20 to 80% RH
	Storage*	5 to 85% RH (without condensation)

* Stored in shipping container

Safety Approvals

Safety standards:	UL 1950 with D3, CSA 22.2 950 with D3
EMC:	FCC part 15 subpart B class B CSA C108.8

Fonts

The printer comes with an installed set of fonts which are selectable using the Default setting mode, described in Chapter 4. However, the printer always uses the fonts you select with your software program. The only time you need to select the printer's installed fonts is when your software program does not allow you to select fonts.

You can select other font and pitch combinations using ESC/P 2 commands, as described in Appendix B.

Scalable fonts

Fonts	Minimum point size	Maximum point size	Increments
EPSON Roman	8	32	2
EPSON Sans Serif	8	32	2
EPSON Roman T	8	32	2
EPSON Sans Serif H	8	32	2

Bitmap fonts

Fonts	10 cpi	12 cpi	15 cpi	Proportional
EPSON Roman	√	√	√	√
EPSON Sans Serif	√	√	√	√
EPSON Courier	√	√	√	N/A

Parallel Interface Specifications

Data format:	8-bit parallel, IEEE-1284 compatible mode
Synchronization:	$\overline{\text{STROBE}}$ pulse
Handshake timing:	BUSY and $\overline{\text{ACKNLG}}$ signals
Signal level:	TTL compatible
Connector:	36-pin Centronics connector or equivalent

Pin Assignments

Signal pin	Return pin	Signal	Direction	Description
1	19	$\overline{\text{STROBE}}$	IN	$\overline{\text{STROBE}}$ pulse to read data.
2	20	DATA 1	IN	These signals represent information in bits 0 to 7 of parallel data respectively. Each signal is at HIGH level when data is logical 1 and LOW when it is logical 0.
3	21	DATA 2	IN	
4	22	DATA 3	IN	
5	23	DATA 4	IN	
6	24	DATA 5	IN	
7	25	DATA 6	IN	
8	26	DATA 7	IN	
9	27	DATA 8	IN	
10	28	$\overline{\text{ACKNLG}}$	OUT	About a 5- μ s pulse. LOW indicates data has been received and the printer is ready to accept more data.

Pin assignments (continued)

Signal pin	Return pin	Signal	Direction	Description
11	29	BUSY	OUT	A HIGH signal indicates the printer cannot receive data. The signal goes HIGH in the following cases: 1) During data entry (for each character) 2) During initialization 3) During self test, demonstration, and default setting printing 4) During a printer-error state
12	28	PE	OUT	A HIGH signal indicates the printer is in a paper-out state or in an error state.
13	28	SLCT	OUT	Pulled up to +5 V through 1 k Ω resistance
14	30	$\overline{\text{AFXT}}$	IN	Not used
15	—	NC	—	Not used
16	—	GND	—	Logic ground level
17	—	CHASSIS GND	—	Printer's chassis ground, which is connected to the logic ground
18	—	Logic H	OUT	Not used
19–30	—	GND	—	Twisted-pair return signal ground level
31	30	$\overline{\text{INIT}}$	IN	When this signal goes LOW, the printer controller is reset to its default state when the power is first turned on and the print buffer is cleared. This level is normally HIGH; its pulse width must be more than 50 μs at the receiving terminal.

Pin assignments (continued)

Signal pin	Return pin	Signal	Direction	Description
32	29	$\overline{\text{ERROR}}$	OUT	This signal level goes LOW when the printer: 1) Is out of paper 2) Is in an error state 3) Has no ink cartridge installed
33	—	GND	—	Same as for pins 19–30
34	—	NC	—	Not used
35	—	+5 V	OUT	Pulled up to +5 V through 1 K Ω resistance
36	30	SLIN	IN	Not used

Notes:

The column heading “Direction” refers to the direction of signal flow as viewed from the printer.

“Return pin” denotes the twisted-pair return pin to be connected at signal ground level. For the interface wiring, be sure to use a twisted-pair cable for each signal and to complete the connection on the return side.

All interface conditions are based on TTL level. Both the rise and fall times of each signal must be less than 0.2 microseconds.

Data transfer must be carried out by observing the $\overline{\text{ACKNLG}}$ or BUSY signal. Data transfer to this printer can be carried out only after receipt of the $\overline{\text{ACKNLG}}$ signal or when the level of the BUSY signal is LOW.

Reverse Channel

Transmission mode:	IEEE-1284 Nibble Mode
Adaptable connector:	5730360 (Amphenol) or equivalent
Synchronization:	Refer to the IEEE-1284 specification
Handshaking:	Refer to the IEEE-1284 specification
Signal level:	IEEE-1284 level 1 device

Data transmission timing:

Refer to the IEEE-1284 specification

Extensibility request:

The printer responds to the extensibility request in the affirmative when the request is 00H or 04H, which means:

00H: Request nibble mode of reverse channel transfer

04H: Request device ID in nibble mode of reverse channel transfer

Reverse channel pin assignments

Pin no.	Signal name	GND	In/Out*	Description
1	HostClk	19	In	Strobe pulse. Input data is latched at falling edge of the signal.
2	DATA0	20	In	These signals represent information in bits 0 to 7 of parallel data respectively. Each signal is at HIGH level when data is logical 1 and LOW when it is logical 0. These signals are used to transfer the 1284 extensibility request values to the printer.
3	DATA1	21	In	
4	DATA2	22	In	
5	DATA3	23	In	
6	DATA4	24	In	
7	DATA5	25	In	
8	DATA6	26	In	
9	DATA7	27	In	
10	PtrClk	28	Out	Used to qualify data being sent to the host. Set LOW then HIGH to cause an interrupt indicating to host that data is available.
11	PtrBusy/ DataBit-3,7	29	Out	Data bits 3 then 7 indicate forward channel busy status.
12	ACkDataReq/ DataBit-2,6	28	Out	Data bits 2 then 6. Set HIGH until host requests data transfer, then follows <i>nData Avail (nFault)</i> .
13	Xflag/ DataBit-1,5	28	Out	X flag signal and reverse channel transfer data bits 1 then 5.

Reverse channel pin assignments (continued)

Pin no.	Signal name	GND	In/Out*	Description
14	HostBusy	30	In	Set LOW to indicate that host can receive peripheral device to host data. Then set high to acknowledge receipt of that nibble. Set high in response to PtrClk (<i>nAck</i>) low pulse to re-enter reverse data transfer phase.
31	$\overline{\text{INIT}}$	30	In	Not used
32	$\overline{\text{DataAvail/}}/$ DataBit-0,4	29	Out	This signal is LOW when the printer is in an error state.
36	1284-Active	30	In	Set HIGH during 1284 mode.
18	Logic H	—	Out	This line is pulled up to +5V through 3.9 k Ω resistance.
35	+5V	—	Out	This line is pulled up to +5V through 1.0 k Ω resistance.
17	Chassis	—	—	Chassis GND
16, 33, 19– 30	GND	—	—	Signal GND
15, 34	NC	—	—	Not connected

* The column heading "In/Out" indicates the direction of signal flow as viewed from the printer.

Timing Chart

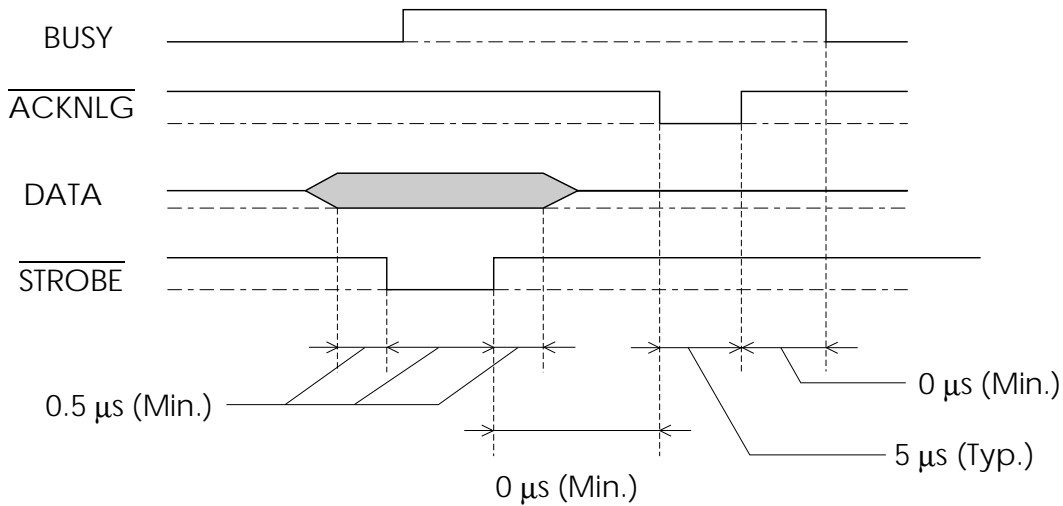

Note: Transition time (both the rise and the fall) of every signal must be less than $0.2 \mu\text{s}$.

Initialization

The printer can be initialized (returned to a fixed set of conditions) in these ways:

Hardware initialization	The printer is turned on <u>or</u> The printer receives an <u>INIT</u> signal from the parallel interface: pin 31 goes LOW
Software initialization	Software sends the ESC @ (initialize the printer) command; the last control panel settings are kept

Both initialization methods reset the font according to the default settings selected using the control panel. However, ESC @ does not initialize the printer mechanism, clear the input data buffer, or clear the user-defined character set.

Default Settings

The table below shows the default settings that take effect when the printer is initialized. In addition, hardware initialization erases any text in the data buffer.

Item	Default setting
Top-of-form position	Current paper position
Page length	Set per the measurement taken at self test
Left and right margins	Cancelled
Line spacing	1/6-inch line spacing
Character pitch	Last font selected using Default setting mode
Vertical tab position	Cleared
Horizontal tab positions	Every eight characters
Font selection	Last font selected using Default setting mode
Special printing effects	Cancelled (except condensed and economy printing)
User-defined character set	Hardware/control panel initialization: cleared Software initialization: deselected only

Commands and Character Tables

Command List	B-2
Character Tables	B-3
International Character Sets	B-7
Characters Available With the ESC (^ Command	B-8



Command List

This printer works with the following ESC/P 2 commands. If you need more information about using printer commands, you can purchase the *ESC/P 2 Reference Manual* (ESCP2REF) from EPSON Accessories by calling **(800) 873-7766** (in the U.S. only). In Canada, call **(800) BUY-EPSON** for sales locations.

General operation:

ESC @, ESC U, ESC EM

Paper feeding:

CR, FF, LF, ESC 0, ESC 2, ESC 3, ESC +

Page format:

ESC (C, ESC C, ESC C 0, ESC Q, ESC 1, ESC (c, ESC N, ESC O

Print position motion:

ESC \$, ESC \, ESC (V, ESC (v, ESC D, HT, ESC B, ESC J, VT

Font selection:

ESC k, ESC x, ESC X, ESC P, ESC g, ESC p, ESC 4, ESC 5, ESC E, ESC F,
ESC !, ESC M

Font enhancement:

ESC W, DC4, SO, DC2, SI, ESC w, ESC G, ESC H, ESC T, ESC S, ESC -,
ESC (-, ESC q

Spacing:

ESC SP, ESC c, ESC (U

Character handling:

ESC t, ESC (t, ESC R, ESC %, ESC &, ESC :, ESC 6, ESC 7, ESC (^

Bit image:

ESC *

Graphics:

ESC (G, ESC ., ESC (e

Color:

ESC r

MicroWeave:

ESC (i

Character Tables

The printer comes with an installed set of character tables. However, when printing from Windows and most DOS software programs, the printer prints the characters you see on screen and does not use its built-in character tables. Unless you're printing from a DOS program, and cannot print the character you need, you should never have to change the character table.

These character tables are selected using the printer's Default setting mode or by using software commands.

All tables except the italic are the same as the PC437 table for hex codes 00 through 7F, so only the PC437 table is shown completely. The rest of the tables show only the characters for hex codes 80 through FF.

PC437 (U.S., Standard Europe)

CODE	0	1	2	3	4	5	6	7	8	9	A	B	C	D	E	F
0	NUL			0	@	P	`	p	Ç	É	á	••••	L	⊥	α	≡
1			!	1	A	Q	a	q	ü	æ	í	••••	⊥	⊥	β	†
2		DC2	"	2	B	R	b	r	é	Æ	ó	••••	⊥	⊥	Γ	≥
3			#	3	C	S	c	s	â	ô	ú	⊥	⊥	⊥	π	≤
4		DC4	\$	4	D	T	d	t	ä	ö	ñ	⊥	⊥	⊥	Σ	∫
5		§	%	5	E	U	e	u	à	ò	Ñ	⊥	⊥	⊥	σ	∫
6			&	6	F	V	f	v	ã	û	ã	⊥	⊥	⊥	μ	∫
7			'	7	G	W	g	w	ç	ù	Ω	⊥	⊥	⊥	τ	∫
8			(8	H	X	h	x	ê	ÿ	¿	⊥	⊥	⊥	ϕ	•
9	HT	EM)	9	I	Y	i	y	ë	Ï	¸	⊥	⊥	⊥	θ	•
A	LF		*	:	J	Z	j	z	è	Ü	¸	⊥	⊥	⊥	Ω	•
B	VT	ESC	+	;	K	[k	{	ï	ϕ	½	⊥	⊥	⊥	δ	∫
C	FF		,	<	L	\	l	;	î	£	¼	⊥	⊥	⊥	δ	∫
D	CR		-	=	M]	m	~	ì	¥	;	⊥	⊥	⊥	∅	∫
E	SO		.	>	N	^	n		Å	℞	«	⊥	⊥	⊥	∅	∫
F	SI		/	?	O	_	o		À	f	»	⊥	⊥	⊥	∅	∫

PC850 (Multilingual)

CODE	8	9	A	B	C	D	E	F
0	Ç	É	á	⋮	Ł	Đ	Ó	±
1	ü	æ	í	⋮	ł	Đ	β	±
2	é	Æ	ó	⋮	Ł	Ê	Ø	±
3	â	ô	ú	⋮	ł	Ê	Ø	±
4	ä	ö	ñ	⋮	Ł	Ê	Ø	±
5	à	ò	ñ	⋮	ł	ı	Ö	±
6	â	û	ä	⋮	Ł	ı	ı	±
7	ç	ù	ö	⋮	ł	ı	ı	±
8	ê	ÿ	ı	⋮	Ł	ı	ı	±
9	ë	ÿ	ı	⋮	ł	ı	ı	±
A	è	Û	ı	⋮	Ł	ı	ı	±
B	ï	ø	ı	⋮	ł	ı	ı	±
C	î	ε	ı	⋮	Ł	ı	ı	±
D	ì	Ø	ı	⋮	ł	ı	ı	±
E	Ë	x	ı	⋮	Ł	ı	ı	±
F	À	f	ı	⋮	ł	ı	ı	±

PC860 (Portuguese)

CODE	8	9	A	B	C	D	E	F
0	Ç	É	á	⋮	Ł	Ł	α	≡
1	ü	À	í	⋮	ł	Ł	β	±
2	é	È	ó	⋮	Ł	Ł	Γ	±
3	â	Ô	ú	⋮	ł	Ł	Π	±
4	ã	Õ	ñ	⋮	Ł	Ł	Σ	±
5	à	Ò	ñ	⋮	ł	Ł	σ	±
6	Á	Ú	ä	⋮	Ł	Ł	μ	±
7	Ç	Ù	ö	⋮	ł	Ł	τ	±
8	ê	ı	ı	⋮	Ł	Ł	ϕ	±
9	Ê	Ï	ı	⋮	ł	Ł	θ	±
A	è	Û	ı	⋮	Ł	Ł	Ω	±
B	ï	ϕ	ı	⋮	ł	Ł	δ	±
C	î	ε	ı	⋮	Ł	Ł	θ	±
D	ì	Û	ı	⋮	ł	Ł	ø	±
E	Ë	ϕ	ı	⋮	Ł	Ł	ε	±
F	À	Ó	ı	⋮	ł	Ł	η	±

PC861 (Icelandic)

CODE	8	9	A	B	C	D	E	F
0	Ç	É	á	⋮	Ł	Ł	α	≡
1	ü	æ	í	⋮	ł	Ł	β	±
2	é	Æ	ó	⋮	Ł	Ł	Γ	±
3	â	ô	ú	⋮	ł	Ł	Π	±
4	ä	ö	Á	⋮	Ł	Ł	Σ	±
5	à	þ	ı	⋮	ł	Ł	σ	±
6	â	Û	Ó	⋮	Ł	Ł	μ	±
7	ç	Ý	Ú	⋮	ł	Ł	τ	±
8	ê	Ý	ı	⋮	Ł	Ł	ϕ	±
9	ë	Ö	ı	⋮	ł	Ł	θ	±
A	è	Û	ı	⋮	Ł	Ł	Ω	±
B	ð	ø	ı	⋮	ł	Ł	δ	±
C	ð	ε	ı	⋮	Ł	Ł	θ	±
D	þ	Ø	ı	⋮	ł	Ł	ø	±
E	Ä	ϕ	ı	⋮	Ł	Ł	ε	±
F	À	f	ı	⋮	ł	Ł	η	±

PC863 (Canadian-French)

CODE	8	9	A	B	C	D	E	F
0	Ç	É	á	⋮	Ł	Ł	α	≡
1	ü	È	ı	⋮	ł	Ł	β	±
2	é	Ê	ó	⋮	Ł	Ł	Γ	±
3	â	Ô	ú	⋮	ł	Ł	Π	±
4	À	È	ı	⋮	Ł	Ł	Σ	±
5	à	Ï	ı	⋮	ł	Ł	σ	±
6	Á	Û	ı	⋮	Ł	Ł	μ	±
7	Ç	Ù	ı	⋮	ł	Ł	τ	±
8	ê	ı	ı	⋮	Ł	Ł	ϕ	±
9	Ê	Ï	ı	⋮	ł	Ł	θ	±
A	è	Û	ı	⋮	Ł	Ł	Ω	±
B	ï	ϕ	ı	⋮	Ł	Ł	δ	±
C	î	ε	ı	⋮	Ł	Ł	θ	±
D	ı	Û	ı	⋮	ł	Ł	ø	±
E	À	Ó	ı	⋮	ł	Ł	ε	±
F	À	ı	ı	⋮	ł	Ł	η	±

PC865 (Nordic)

CODE	8	9	A	B	C	D	E	F
0	Ç	É	á	⋯	Ł	⊥	α	≡
1	ü	æ	í	⋯	Ł	⊥	β	±
2	é	Æ	ó	⋯	⊥	⊥	Γ	≥
3	â	Ô	ú	⋯	⊥	⊥	Π	≤
4	ä	Ö	ñ	⋯	⊥	⊥	Σ	∫
5	à	ò	Ñ	⋯	⊥	⊥	σ	∫
6	â	û	ä	⋯	⊥	⊥	μ	÷
7	ç	ù	ö	⋯	⊥	⊥	τ	≈
8	ê	ÿ	¿	⋯	⊥	⊥	Φ	°
9	ë	ÿ	¿	⋯	⊥	⊥	Θ	·
A	è	Û	¿	⋯	⊥	⊥	Ω	·
B	ï	ø	½	⋯	⊥	⊥	δ	√
C	î	ø	¼	⋯	⊥	⊥	ø	n
D	ì	Ø	i	⋯	⊥	⊥	ø	²
E	Ä	Pt	«	⋯	⊥	⊥	€	■
F	Å	f	»	⋯	⊥	⊥	€	■

Abicom

CODE	8	9	A	B	C	D	E	F
0	NUL			Ò	ì	ò		
1			À	Ó	à	ó		
2		DC2	Á	Ô	á	ô		
3			Ä	Õ	ä	ö		
4		DC4	Å	Ö	å	ö		
5			Æ	Œ	æ	œ		
6			Ç	Û	ç	ù		
7			È	Û	è	ú		
8			É	Û	é	û		
9	HT	EM	Ê	Û	ê	ü		
A	LF		Ë	ÿ	ë	ÿ		
B	VT	ESC	Ì	·	ì	ß		
C	FF		Í	·	í	ä		
D	CR		Î	·	î	ö		
E	SO		Ï	·	ï	¿		
F	SI		Ñ	·	ñ	±	DEL	

BRASCI

CODE	8	9	A	B	C	D	E	F
0	NUL			°	À	Ð	à	ð
1			í	±	Á	Ñ	á	ñ
2		DC2	¢	²	Â	Ò	â	ò
3			£	³	Ã	Ó	ã	ó
4		DC4	¤	´	Ä	Ô	ä	ô
5			¥	µ	Å	Õ	å	õ
6			¦	¶	Æ	Ö	æ	ö
7			§	·	Ç	Œ	ç	œ
8			¨	¸	È	Ø	è	ø
9	HT	EM	©	¹	É	Ù	é	ù
A	LF		ª	º	Ê	Û	ê	ú
B	VT	ESC	«	»	Ë	Ü	ë	ü
C	FF		¼	¼	Ì	Ü	ì	ü
D	CR		½	½	Í	Ý	í	ý
E	SO		¾	¾	Î	Þ	î	þ
F	SI		¿	¿	Ï	ß	ï	ÿ

Italic

CODE	8	9	A	B	C	D	E	F
0	NUL			0	@	P	`	p
1			!	1	A	Q	a	q
2		DC2	"	2	B	R	b	r
3			#	3	C	S	c	s
4		DC4	\$	4	D	T	d	t
5			%	5	E	U	e	u
6			&	6	F	V	f	v
7			'	7	G	W	g	w
8			(8	H	X	h	x
9	HT	EM)	9	I	Y	i	y
A	LF		*	:	J	Z	j	z
B	VT	ESC	+	;	K	[k	{
C	FF		,	<	L	\	l	;
D	CR		-	=	M]	m	}
E	SO		.	>	N	^	n	~
F	SI		/	?	O	_	o	

No characters are available for hex code 15 in the italic character table.

International Character Sets

You can select one of the following international character sets using the printer's Default setting mode or the ESC R command. For example, when you select "Italic France," the characters in the "France" row on the table below are used in the italic character table.

The following eight international character sets can be selected using Default setting mode or the ESC R command.

Country	ASCII code hex											
	23	24	40	5B	5C	5D	5E	60	7B	7C	7D	7E
USA	#	\$	@	[\]	^	'	{		}	~
France	#	\$	à	°	ç	§	^	'	é	ù	è	¨
Germany	#	\$	§	Ä	Ö	Ü	^	'	ä	ö	ü	ß
UK	£	\$	@	[\]	^	'	{		}	~
Denmark	#	\$	@	Æ	Ø	Å	^	'	æ	ø	å	~
Sweden	#	¤	É	Ä	Ö	Å	Û	é	ä	ö	å	ü
Italy	#	\$	@	°	\	é	^	ù	à	ò	è	ì
Spain	Pt	\$	@	ı	Ñ	ı	^	'	¨	ñ	}	~

The following seven additional sets can be selected only with the ESC R command.

Country	ASCII code hex											
	23	24	40	5B	5C	5D	5E	60	7B	7C	7D	7E
Japan	#	\$	@	[¥]	^	'	{		}	~
Norway	#	¤	É	Æ	Ø	Å	Û	é	æ	ø	å	ü
Denmark II	#	\$	É	Æ	Ø	Å	Û	é	æ	ø	å	ü
Spain II	#	\$	á	ı	Ñ	ı	é	'	ı	ñ	ó	ú
Latin America	#	\$	á	ı	Ñ	ı	é	ü	ı	ñ	ó	ú
Korea	#	\$	@	[₩]	^	'	{		}	~
Legal	#	\$	§	°	'	"	¶	'	©	®	†	™

Characters Available With the ESC (^ Command

To print the characters in the table below, use the ESC (^ command.

CODE	0	1	7
0		▶	
1	☺	◀	
2	☹	↕	
3	♥	!!	
4	♦	¶	
5	♣		
6	♠	-	
7	•	↕	
8	■	↑	
9	○	↓	
A	◉	→	
B	♂	↑	
C	♀	└	
D	♪	↔	
E	♫	▲	
F	⊛	▼	△

Glossary

auto line feed

When this feature is selected in the printer's Default setting mode, each carriage return (CR) code is automatically followed by a line feed (LF) code.

bidirectional printing

Printing in which the print head prints in both directions (bidirectionally). This increases print speed but may reduce precise vertical alignment. Also called *high speed printing*.

brightness

The lightness or darkness level of an image.

character table

The collection of letters, numbers, and symbols that constitute the set of characters used in a particular language.

CMY

A method of specifying and creating colors using Cyan (blue-green), Magenta, and Yellow.

contrast

The difference between the darkest and lightest colors in an image. The greater the difference, the higher the contrast.

control code

A special code used to control a printer function such as performing a carriage return or line feed.

default

A value or setting that takes effect when the equipment is turned on, reset, or initialized.

dithering

A way of arranging dots on a page to simulate a shade or tone. See also *halftoning*.

dpi

Dots per inch. Print resolution is measured in dpi. See also *resolution*.

driver

See *printer driver*.

economy printing

Printing in which images are printed with fewer dots to save ink. Economy mode printing is faster, too.

error diffusion

A halftoning method where dot patterns are randomly distributed in an image to create soft edges.

ESC/P®

EPSON Standard Code for Printers. The system of commands sent by the computer to control the printer. It is standard for all EPSON printers and supported by most application software for personal computers.

ESC/P 2

Enhanced version of the ESC/P printer command language.

font

A style of type designated by a family name, such as Courier.

grayscale

An image consisting of multiple shades of gray, ranging from white to black.

halftoning

Method of repeating tiny dot patterns to represent images.

hex dump

A troubleshooting feature that helps advanced users find the cause of communication problems between the printer and the computer. When the printer is in hex dump mode, it prints each code it receives in hexadecimal notation and ASCII characters. Also called data dump.

high-speed printing

Printing in which images are printed in both directions to increase print speed. Also called *bidirectional printing*.

initialization

The process of restoring the printer's default settings (fixed set of conditions).

ink jet

A method of printing in which the printer produces images and characters by precisely spraying ink onto paper or other media.

interface

The connection (via a cable) between the computer and the printer over which print data is transmitted to the printer.

media

Materials upon which data is printed such as envelopes, plain paper, coated or glossy paper, and transparency film.

MicroWeave

A printing method in which images are printed in finer increments to reduce the possibility of banding and to produce laser-like images.

monochrome printing

Printing in only one color. For the Stylus COLOR 200, monochrome printing refers to printing with black ink.

printable area

The area of a page on which the printer can print. It is smaller than the physical size of the page due to margins.

printer driver

A software program that sends commands for using the features of a particular printer.

print head unit

The printer mechanism that contains the ink cartridge and distributes the ink onto printing media.

printing mode

A driver setting that assigns the number of dots per inch used to represent an image. Your printer has three printing mode settings: Super - 720 dpi, Best - 360 dpi, and Economy (180 dpi). See also *resolution*.

reset

To return a printer to its default settings.

resolution

A measure of the amount of detail that can be represented. Resolution of printed images is measured in number of dots per inch (dpi). Your printer has three resolution settings: 720 × 720, 360 × 360, and 180 × 180 dpi. See also *printing mode*.

RGB

A method of specifying color by its component proportion of red, green, and blue. Computer monitors use this method to represent colors.

saturation

The degree to which a color is undiluted by white light. The more saturated the color, the more pure and bright it is.

self test

A method for checking the operation of the printer. When you run the self test, the printer prints the characters stored in its memory.

unidirectional printing

Printing in which the print head prints in one direction only.

Unidirectional printing is useful for printing graphics because it allows precise vertical alignment.

Index

A

- Accessing printer driver, 2-9–10
- Accessories, purchasing, Intro-2, Intro-7, 3-2–3, 5-7, B-2
- Adjusting thickness levers, 3-3–5, 6-4, 6-15
- Aligning vertical lines, 4-8, 5-12–16, 6-6
- Apply button, 2-14
- Auto line feed, 4-9
- Auto sheet feeder
 - capacity, 3-5, 3-8–9, 3-11, A-3
 - loading, 3-5
 - option, 2-13
 - specifications, A-2
- Automatic driver settings, 2-12–13, 6-5

B

- Banding, 6-6
- Best - 360 dpi option, 2-13
- Bidirectional printing, 4-8, 6-12
- Black ink cartridge, *see* Ink cartridges
- Blank pages, 6-10
- Blue Strength option, 2-14, 6-7
- Blurred images, 6-4–5
- Bottom margin, 6-7, A-5
- Brightness, 6-5, 6-7
- Buffer, input, A-2
- Buttons, control panel, 4-5–6, 4-8

C

- Cable, printer, 1-2, 1-18, 6-6, 6-8–9, 6-12
- Calibration Utility, 2-2, 5-12–16, 6-6
- Cancel button, 2-14

- Carriage return character, 4-9
- Cartridges, *see* Ink cartridges
- Character pitch, 4-9, A-15
- Character tables, 4-8, A-3, B-3–8
- Choosing paper, 3-2–3
- Cleaning
 - button, 4-6–9
 - print heads, 4-6, 5-2–3, 5-12, 6-3–4
 - printer, 5-10–11
- Coated papers, 2-13, 3-2–3, 3-8–10, 4-7, A-3–5
- Collate setting, 2-13
- Color
 - balance, 2-12, 2-14
 - head unit option, 2-13, 6-5
 - incorrect, 6-7
 - ink cartridges, *see* Ink cartridges
 - matching, Intro-4, 2-12, 2-14, 6-7
- Color Balance setting, 2-12, 2-14
- Color Matching setting, 2-12, 2-14
- Commands
 - ESC (^, B-8
 - ESC @, A-14
 - ESC R, B-7
 - ESC/P 2, 2-8, A-8, B-2
- CompuServe, Intro-8
- Connecting printer, 1-18
- Contrast, 6-5, 6-7
- Control panel, 4-2, 4-5–8, 6-2, 6-8–9
- Controlling the printer
 - with Default setting mode, 4-7–9
 - with Spool Manager, 4-2–4
 - with the control panel, 4-5–9
- Copies, number of, 2-13, 6-15
- Customer support, Intro-6–8

D

Dampness, *see* Humidity
Default setting mode, 4-8-9
Default settings
 at initialization, A-15
 printer, 4-7-9, 6-7, B-7
 printer driver, 2-12-14, 6-6-7, 6-12
 printer port, 2-3-4
 Windows printer, 2-3-4, 2-6, 6-6-7, 6-10, 6-12
Demonstration page, 4-6, 5-2-3, 6-3, 6-6-7, 6-12
Despooler, 4-2-4, 6-2-3
Diagnosing problems, 6-2-3
Dialog box
 Despooler, 4-2-4
 Print, 2-9
 Print Setup, 2-9
 printer driver, 2-2, 2-11, 2-13-14
Diffusion, error, 2-14
Dimensions, printer, A-7
Diskettes, 1-3, 2-2
Dithering options, 2-14
Document Type option, 2-12-13, 6-5-6
DOS
 calibration utility, 5-14-16
 character tables, 4-8, A-3, B-3-8
 economy mode, 4-9, 6-7
 printer drivers, 2-8
Download service, Intro-8
Dpi, Intro-1-2, A-2
Driver, *see* Printer driver

E

Economy
 default setting mode, 4-9, 6-7
 document type option, 2-13, 6-6
 printing mode option, 2-13
Edge guides, 1-15-16, 3-6-11, 6-14
Electrical specifications, A-7
Electronic support services, Intro-7-8

Energy Star compliance, Intro-4
Energy, conserving, Intro-4-5
Envelopes
 driver options, 2-13
 loading, 3-11
 specifications, A-4-5
Environmental specifications, 1-4, A-8
EPSON
 Accessories, Intro-2, Intro-7, 3-2-3, 5-7, B-2
 America Forum, Intro-8
 Customer Care Centers, Intro-6
 Download Service, Intro-8
 Fax-on-Demand service, Intro-8
 FTP site, Intro-7
 World Wide Web site, Intro-7
Error diffusion option, 2-14
Error handling, *see* Troubleshooting
ESC (^ command, B-8
ESC @ command, A-14
ESC R command, B-7
ESC/P 2 commands, 2-8, A-8, B-2

F

Factory defaults, 4-7-9, A-15
Faint images, 6-4-5
Fax-on-Demand service, Intro-8
Feeder, *see* Auto sheet feeder
Feeding problems, 6-14-15
Film, *see* Transparencies
Fonts
 default selection, 4-9, A-8-9, A-15
 list of, A-8-9
FTP site, Intro-7

G

Garbled characters, 6-6-7
Glossy paper, 2-13, 3-2-3, 3-8-10, 4-7, A-3-5
Graph option, 2-13
Graphics menu tab, 2-11, 2-14
Green Strength option, 2-14, 6-7

H

Halftoning setting, 2-14
Handshake timing, A-9, A-11
Hard disk space, Intro-3, 1-2
Head Unit setting, 2-12–13, 3-10, 6-5
Help
 from EPSON, Intro-6–8
 online driver, 2-12, 2-15, 6-3
 online Spool Manager, 4-2
Hex dump mode, 4-7–8, 6-13
High Speed mode, 2-13, 6-4
Horizontal tab positions, A-15
Humidity, 6-5, 6-14–15, A-4, A-8

I

Incorrect
 characters, 6-6–7
 color, 6-7
 margins, 6-7
Initialization, A-14–15
Ink cartridges
 installing, 1-6–14
 life expectancy, 6-9, 6-11, A-6
 monitoring capacity, 4-4
 old, 6-9, 6-11
 ordering, Intro-7, 5-7
 print capacity, A-6
 replacing, 5-6–10, 6-8–9
 selecting correct, 5-7
 specifications, A-6–7
 unpacking, 1-6, 1-9
Ink delivery system, charging,
 1-6–14, 5-10
Ink Out light, 4-5, 5-6
Input buffer, A-2
Interface, Intro-1, 1-18, A-9–14
International character sets, B-7
Internet, Intro-7
Italic character set, B-6

J

Jammed paper, preventing, 6-13–14

L

Labels, 3-6–8
Landscape setting, 2-13
Left edge guide, 3-6–11, 6-14
Left margin, A-5, A-15
Lights, control panel, 4-5, 6-2, 6-8–9
Line feed, auto, 4-9
Line spacing, A-3, A-15
Lines, aligning, *see* Vertical lines,
 aligning
Load/Eject button, 4-6–9
Loading
 coated papers, 3-8–10
 envelopes, 3-11
 glossy paper, 3-8–10
 plain paper, 1-15–17, 3-5–7
 transparencies, 3-8–10
Loading position, adjusting, 4-9
Location, selecting, 1-4

M

Main menu tab, 2-11–13
Maintenance, 5-1–16
Managing print jobs, 4-2–4
Manuals, how to use, Intro-5–6
Margins
 left and right, A-5, A-15
 top and bottom, 4-9, 6-7, A-5
Mechanical specifications, A-7
Media Type setting, 2-12–13, 3-7,
 3-10, 6-4, 6-11
Microsoft Windows, *see* Windows
MicroWeave option, 2-8, 2-13, 6-4,
 6-6
Monitoring ink cartridge capacity,
 4-4

Monitoring print jobs, 4-2-4, 6-6,
6-10-12

Monochrome

head unit option, 2-12-13, 6-5
print speed setting, 4-9
printing, 2-13, 5-3, A-2

Moving the printer, *see* Transporting
the printer

N

Network interface mode, 4-8

No halftoning option, 2-14

Non-smear printing mode, 3-5, 4-7

Notice Sheet, 1-3, 1-5

Nozzles, print head, 5-2, A-2

O

Online

driver help, 2-12, 2-15, 6-3
Spool Manager help, 4-2
support, Intro-7-8

Orientation of paper, 2-13

P

Packaging, 1-3, 5-11-12

Page length, 6-7, A-15

Paper

coated, 2-13, 3-2-3, 3-8-10, 4-7, A-3-5
copies setting, 2-13, 6-15
ejecting, 4-6
envelopes, *see* Envelopes
feed speed, A-2
feeding problems, 6-14
glossy, 2-13, 3-2-3, 3-8-10, 4-7, A-3-5
handling problems, 6-13-15
jam problems, 6-8, 6-13
labels, 3-6-8
loading envelopes, 3-11
loading plain paper, 1-15-17, 3-5-7
loading special paper, 3-8-10

Paper (continued)

ordering, Intro-2, Intro-7, 3-2-3
orientation setting, 2-13
plain, *see* Plain paper
printable area, A-5
printable surface, 1-15, 3-5-6, 3-8,
3-10-11, 6-4
selecting type, 2-12-13, 3-2-3
size, 2-12-13, 3-11, 6-7, 6-10, A-3
source setting, 2-13
special, *see* Special papers
specifications, A-3-5
storing, 3-8, 6-5
transparencies, *see* Transparencies
types, 3-2-3, 6-4, A-3
weight, A-3-4
wrinkled, 6-15

Paper jams, preventing, 6-13-14

Paper Out light, 4-5

Paper support, 1-4, 1-17

Paper thickness lever, 1-14-15,
3-3-4, 6-4, 6-15

Parallel interface, Intro-1, 1-2, 1-18,
A-9-14

Pausing print jobs, 4-3

Photo option, 2-13

Pin assignments, A-9-13

Pitch, character, 4-9, A-15

Plain paper

driver option, 2-13
loading, 1-15-17, 3-5, 3-7

Plug-and-play, 2-5-7

Plugging in printer, 1-5

Portrait setting, 2-13

Power

consumption, A-7
cord, 1-5
light, 4-5
switch, 1-5, 4-6-8

Print

dialog box, 2-9
direction, 4-2, 4-8, A-2
options, 2-13

Print heads

- cleaning, 1-18, 4-6, 5-2-3, 5-12, 6-3-4
- driver selection, 2-12-13, 3-10, 6-5
- installing, 1-6, 1-12-14, 6-8
- nozzles, 5-2, A-2
- replacing, 1-11-14, 5-3-6

Print jobs, managing, 4-2-4

Print quality

- improving, 1-18, 5-2-3, 6-3-4
- problems with, 6-3-7

Print speed

- increasing, 4-8, 6-6, 6-11
- monochrome, 4-9
- specifications, A-2

Printable area, A-5

Printable surface, 1-15, 3-5-6, 3-8, 3-10-11, 6-4

Printer

- cable, 1-2, 1-18, 6-6, 6-8-9, 6-12
- calibrating, 2-2, 5-12-16
- cleaning, 5-10-11
- connecting, 1-18
- control panel, 4-2, 4-5-9, 6-2, 6-8-9
- defaults, 4-7-9
- dimensions, A-7
- driver, *see* Printer driver
- hex dump mode, 4-7-8, 6-13
- loading position, 4-9
- non-smear mode, 4-7
- plugging in, 1-5
- port, 2-3-4
- problems, *see* Troubleshooting
- self test, 1-17-18, 4-6, 6-9
- setting up, 1-1-18
- specifications, A-1-16
- testing, 1-17-18, 4-6
- transporting, 1-3, 5-11-12
- turning on and off, 1-5
- unpacking, 1-3
- weight, A-7

Printer driver

- accessing, 2-9-10
- changing settings, 2-14
- color matching option, 2-14
- default settings, 2-12-14, 6-6-7, 6-12
- dialog box, 2-11, 2-13-14
- diskettes, 1-3, 2-2
- DOS, 2-8
- Graphics menu tab, 2-11, 2-14
- help, 2-12, 2-15
- installing, 2-2-8, 6-9
- Main menu tab, 2-11-13
- online help, 2-12, 2-15
- using, 2-9, 2-11-15
- utilities, 2-2

Printing

- canceling, 4-3
- conflicts, 6-10
- demonstration, 4-6, 5-3, 6-3, 6-6-7, 6-12
- direction, 4-2, 4-8, 6-12
- managing, 4-2-4
- pausing, 4-3
- problems with, *see* Troubleshooting
- restarting, 4-3
- smear ink, 3-5
- specifications, A-2-3
- speed, *see* Print speed
- testing, 1-17-18, 4-6, 6-9

Printing Mode setting, 2-12-13, 6-11

Problems, *see* Troubleshooting

Processor requirements, 1-2

Q

Quality, *see* Print quality

Quick Setup card, 1-3

R

- RAM requirements, 1-2
- ReadMe, 6-3
- Red Strength option, 2-14, 6-7
- Registration card, 1-3
- Resolution
 - selecting, 2-12–13, 6-11
 - specifications, A-2
- Restarting print jobs, 4-3
- Restore Defaults button, 2-14
- Reverse channel, parallel interface, A-11–13
- Reverse page order setting, 2-13
- Right margin, A-5, A-15

S

- Safety approvals, A-8
- Safety instructions, Intro-9
- Saturation option, 2-14, 6-7
- Scanned images, 6-4
- Self test, 1-17–18, 4-6, 6-9
- Service, Intro-6–8
- Setting up printer, 1-1–18
- Setup program, printer software, *see* Printer driver
- Sheet feeder, auto, *see* Auto sheet feeder
- Size, paper, *see* Paper
- Smearred ink, 3-5, 4-7
- Software, *see* Printer driver
 - see also* Calibration Utility and Spool Manager
- Spacing, line, A-3
- Special papers
 - driver options, 2-13
 - loading, 3-8–11
 - ordering, 3-2–3
 - selecting, 3-2–3
 - specifications, A-3–5
 - storing, 6-5

- Specifications, A-1–16
- Spool Manager, 2-2, 4-2–4, 6-6, 6-10–12
- Status Monitor, 4-2–4, 6-2–3, 6-11
- Super - 720 dpi option, 2-13, 3-10
- Support services, Intro-6–8
- System requirements, 1-2

T

- Tab positions, A-15
- Technical assistance, Intro-6–8
- Telephone numbers, Intro-6–8
- Temperature, A-4, A-6, A-8
- Temporary directories, 6-10
- Testing the printer, 1-17–18, 4-6, 6-9
- Thickness adjustment lever, 3-3–5, 6-4, 6-15
- Timing
 - chart, A-14
 - handshake, A-9, A-11
- Top margin, 4-9, 6-7, A-5
- Transparencies
 - driver option, 2-13
 - loading, 3-8–10
 - printing problems, 6-4
 - selecting, 3-2–3
 - specifications, A-3–5
- Transporting the printer, 1-3, 5-11–12
- Troubleshooting, 6-1–16
- Turning the printer on and off, 1-5

U

- Unidirectional printing, 4-8
- Unpacking the printer, 1-3
- Updating Windows version, 2-3, 6-9
- User-defined
 - character set, A-15
 - paper size, 2-13

V

- Vertical lines, aligning, 4-8, 5-12-16, 6-6
- Vertical tab position, A-15
- VGA
 - driver, 6-5
 - monitor, 1-2
- Video option, 2-13

W

- Weight
 - paper, A-3-4
 - printer, A-7
- What's This? prompt, 2-15
- Windows
 - calibration, 5-12-14
 - color matching option, 2-14
 - default printer, 2-3-4, 2-6, 6-6-7, 6-10, 6-12
 - plug-and-play, 2-5-7
 - printer driver, *see* Printer driver
 - supported versions, 1-2
 - updating version, 2-3, 6-9
 - VGA driver, 6-5
- World Wide Web, Intro-7
- Wrinkled paper, 6-15